

## Overview

The FireworX FX-PDD Duct Smoke Detector is designed for easy installation and represents the perfect balance of practical design and advanced technology.

The FX-PDD features a unique design that speeds installation and simplifies maintenance. Removable dust filters, conformally coated circuit boards, and optional water-resistant gaskets keep contaminants away from components, ensuring years of trouble-free service. When cleaning is required, the assemblies come apart easily and snap back together in seconds.

The duct smoke detector's primary purpose is to provide early warning of an impending fire and shut down the HVAC unit in order to prevent smoke from circulating throughout the building. The duct smoke detector is designed for use in duct applications where temperatures can exceed standard detector capabilities.

**WARNING:** Duct detectors have specific limitations. Duct detectors are not a substitute for an open area smoke detector. Duct detectors are not a substitute for early warning detection or a replacement for a building's regular fire detection system. Smoke detectors are not designed to detect toxic gases which can build up to hazardous levels in some fires. These devices will not operate without electrical power. As fires frequently cause power interruptions, GE Security suggests you discuss further safeguards with your local fire protection specialist.

## Standard Features

- Less than 2" deep for easy installation and applications where space is tight
- 32 to 120 °F (0 to 50 °C) operating range with 100 ft/min. to 4,000 ft/min air velocity rating assures reliability under harsh environmental conditions
- Status LEDs remain visible through clear assembly cover
- Cover monitor switch for added security
- Standard sampling tube spacing for easy drop-in migration from other detectors
- Sampling tube can be installed with or without the cover in place and can be rotated in 45-degree increments to ensure proper alignment with duct airflow
- 15.2 to 19.95 Vdc operation
- Magnet-activated test switch
- One Form C auxiliary alarm relay for controlling ancillary equipment (e.g., HVAC controls)
- No special tools required for easy access to field connections
- Environmental compensation with differential sensing for reliable, stable, and drift-free sensitivity
- Wide 0.79% to 2.46% obscuration/ft. smoke sensitivity
- Identification of dirty or defective detectors

# Intelligent Duct Smoke Detector

FX-PDD



## Application

The FX-PDD duct detector is ideally suited to duct smoke detection applications where early indication of combustion is required within the confined space of ventilation ductwork. Its primary purpose is to provide early warning of an impending fire and to prevent smoke from circulating throughout the building. It is typically used to detect smoke in the supply side of the HVAC system but can provide supervision of the return side as well.

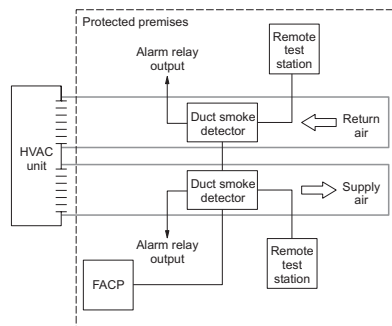

FX-PDD detectors continually sample air flow in the HVAC duct and initiate an alarm condition whenever smoke is detected. An alarm is activated when the quantity (percent obscuration) of combustion products in that air sample exceeds the detector's sensitivity setting.

### FX-Series Intelligence

Like all FX-Series intelligent devices, the FX-PDD detector features rotary addressing and issues a dirty sensor warning when it reaches its preset limit. The dirty sensor warning indicates the sensor is operating within its specified limits but is in need of servicing. When the detector's ability to compensate for environmental changes has reached its limit, the duct smoke detector signals a trouble condition.

The FX-PDD also uses differential sensing to prevent gradual environmental changes from triggering unwanted alarms. A rapid change in environmental conditions, such as smoke from a fire, causes the detector to signal an alarm state, but dust and debris accumulated over time does not change alarm sensitivity.

Each FX-PDD detector contains a microprocessor that performs comprehensive self-diagnostics and stores the results in nonvolatile memory. Stored results include details such as hours of operation, last maintenance date, and number of alarms and troubles. This information can be retrieved and reviewed when desired.

### Detector Configuration

The detector assembly cover provides easy access to the smoke sensor, its wiring connections, sample and exhaust tubes, and the smoke chamber itself.

Air enters the detector's sensing chamber through a sampling tube (ordered separately) that extends into the duct and is directed back into the ventilation system through an exhaust tube (included). The difference in air pressure between the two tubes pulls the sampled air through the sensing chamber. When a sufficient amount of smoke is detected in the sensing chamber, the detector initiates an alarm.

The sampling tube may be installed from either the duct side of the assembly or from inside the sensor compartment, as preferred by the installer. (The exhaust tube must be installed from the duct side.) Sampling tubes may be rotated in 45-degree increments so that air-holes can be aligned to allow the unit to be mounted at virtually any angle relative to the air flow.

In installations where the duct smoke detector's controls and indicators are hidden from view, a remote test station or an LED indicator can be connected to the detector to provide these functions.

## Remote Test Stations



Labor-saving Remote Test/Reset stations provide alarm testing from the convenience of a remote location. Tests can be performed quickly and safely – without having to climb to the roof. Magnetically-operated and key-operated one-gang models are available. FX-PDD detectors are also compatible with R-LED remote alarm LED.

Air velocity in the duct as low as 100 ft/min. maintains adequate air flow into the sensor smoke chamber through air holes in the air sampling tube and discharges through the exhaust tube. Air sampling tubes must be installed with the inlet holes facing the airstream. Sampling tubes may be rotated in 45-degree increments so that air-holes can be aligned to allow the unit to be mounted in virtually any angle relative to the airflow.

FX-PDD sensors are engineered to operate optimally under the harsh environmental conditions frequently found in HVAC ductwork. Nonetheless, before installing the detector, test the duct air velocity, temperature, and humidity to verify that it is within the operating range of the detector. Consult the FX-PDD installation sheet for details.

### Test station specifications

Remote Test/Reset Stations provide alarm test, trouble indication, and reset capability from a remote location. They include a one-gang plate, momentary SPST switch, red alarm LED, and terminal block. Magnetically-operated models (TRM) or key-operated models (TRK) are available.

|                             |  |
|-----------------------------|--|
| Compatible electrical boxes | North American 1-gang box Standard 4-in square box, 1-1/2 inches deep, with 1-gang cover |
| LED indicators              | Alarm (red)  |
| LED type                    | Clear lens   |
| Wire size                   | 14 to 22 AWG   |
| Resistance per wire         | 10 Ohms, max.  |
| Current requirements        | See controller specifications  |
| LED circuit ratings         | Voltage: 3 Vdc, max. Current: 30 mA, max.  |
| Switch ratings (SD-TRK)     | Voltage: 125 Vdc, max. Current: 4 A, max.  |
| Switch ratings (SD-TRM)     | Voltage: 200 Vdc, max. Current: 0.5 A, max.  |
| Operating environment       | 32 to 120 °F (0 to 50 °C)<br>Humidity: 93% RH, noncondensing                             |
| Storage temperature         | -4 to 140 °F (-20 to 60 °C)  |
| Agency listings             | UL, ULC, CSFM  |

## Detector Addressing

Use a screwdriver to adjust the two rotary switches on the front of the module. Set the TENS rotary switch (0 through 12) for the 10s and 100s digit and the ONES rotary switch for the 0 through 9 digit.

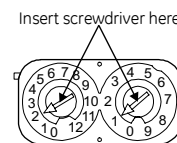

## Jumper Settings

JP1 Determines the operation of the detector:

**1-2 Alarm Factory Default:** Configures the detector for alarm latching operation.

**2-3 Supervisory:** Configures the detector for supervisory operation.

## Assembly

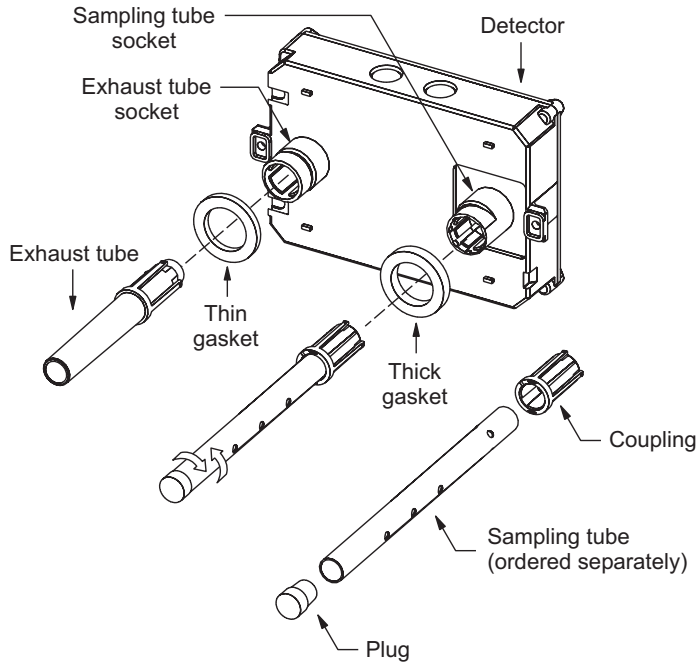

## Mounting

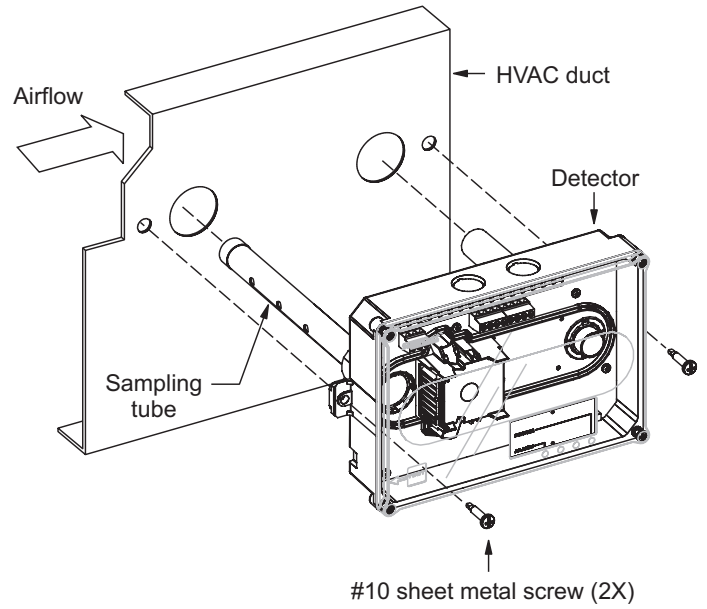

## Wiring

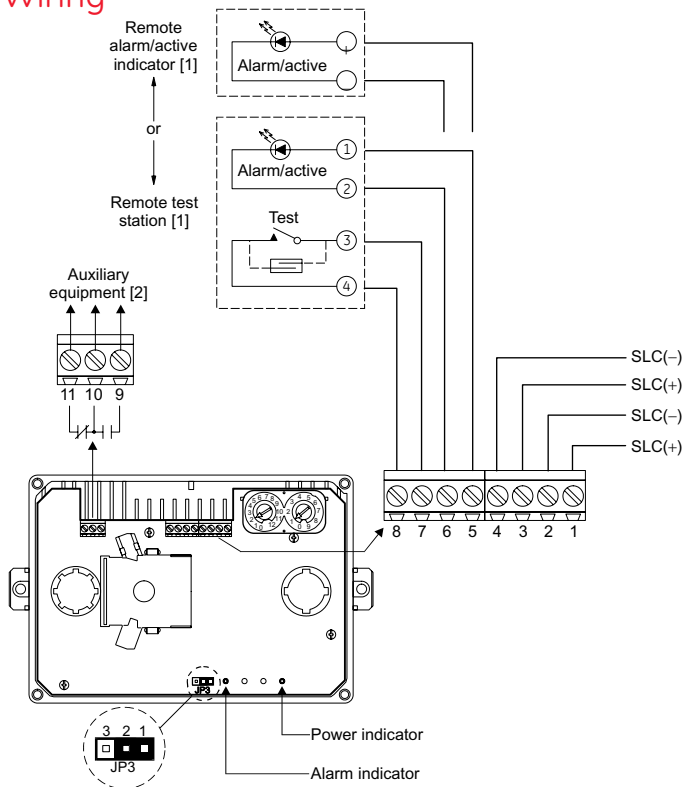

### Notes

- 1] No more than one remote test station or LED indicator can be connected to the detector at the same time. Wiring is unswitched. Maximum wire resistance is 10 ohms per wire.
- 2] Power-limited when connected to a power-limited source. If connected to a nonpower-limited source, all power-limited wiring in box must use FPL, FPLR, or FPLP cable or equivalent per NEC.

## Dimensions

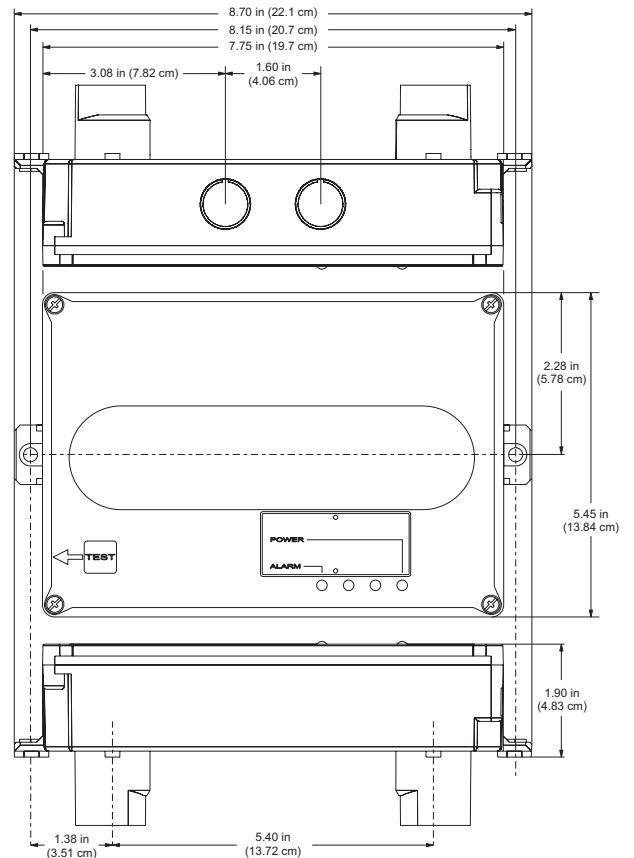

U.S.  
T 888-GESECURITY  
F 503-691-7566

Canada  
T 519 376 2430  
F 519 376 7258

Asia  
T 852 2907 8108  
F 852 2142 5063

Latin America  
T 305 593 4301  
F 305 593 4300

[www.gesecurity.com/fireworx](http://www.gesecurity.com/fireworx)

© 2009 General Electric Company  
All Rights Reserved

## Detector specifications

|   |   |
|---|---|
| Communication line voltage                    | Maximum 20 V peak-to-peak   |
| Operating current                             |   |
| Normal  | 45 µA   |
| Alarm   | 45 µA   |
| Inrush  | 1 mA  |
| Common alarm relay/auxiliary equipment        | Unsupervised and power-limited Quantity: 1 Type: Form C Rating: 2.0 A at 30 VDC (resistive)   |
| Air velocity                                  | 100 to 4,000 ft./min  |
| Air pressure differential                     | 0.005 to 1.00 inches of water   |
| Smoke sensitivity range                       | 0.79 to 2.46%/ft. obscuration   |
| Smoke detection method                        | Photoelectric (light scattering principle)  |
| Alarm test response time                      | 5 seconds   |
| Dimensions                                    | 8.70 x 5.45 x 1.90 inches   |
| Operating environment                         | 32 to 120 °F (0 to 50 °C)   |
| Temperature Humidity                          | 0 to 93% RH, noncondensing  |
| Wire size                                     | 14 to 22 AWG wire   |
| Detector address                              | 01 to 64 (64 point control panel) 01 to 127 (127 point control panel)   |
| Accessories SD-TRM SD-TRK SD-MAG SD-VTK R-LED | Remote test-reset station, magnetic Remote test-reset station, keyed Test magnet kit Air velocity test kit Remote LED alarm indicator |

## Ordering Information

| Catalog Number     | Description                                | Ship Wt., lb. (kg) |
|--------------------|--|--------------------|
| FX-PDD             | Intelligent Addressable Duct Detector      | 2.4 (1.1)          |
| <b>Accessories</b> |  |                    |
| SD-T8              | 8-inch sampling tube                       | 0.5 (0.2)          |
| SD-T18             | 18-inch sampling tube                      | 1.5 (0.7)          |
| SD-T24             | 24-inch sampling tube                      | 2.7 (1.2)          |
| SD-T36             | 36-inch sampling tube                      | 3.0 (1.4)          |
| SD-T42             | 42-inch sampling tube                      | 3.5 (1.6)          |
| SD-T60             | 60-inch sampling tube                      | 5.8 (2.6)          |
| SD-T78             | 78-inch sampling tube                      | 7.5 (3.4)          |
| SD-T120            | 120-inch sampling tube                     | 11.5 (5.2)         |
| R-LED              | Remote alarm LED                           | 1.0 (0.5)          |
| SD-TRM4            | Remote test station, magnetic              | 1.0 (0.5)          |
| SD-TRK4            | Remote test station, keyed                 | 1.0 (0.5)          |
| SD-VTK             | Air velocity test kit (stoppers only, etc) | 1.0 (0.5)          |
| SD-MAG             | Test magnet kit                            | 0.5 (0.2)          |
| FX-SDPCB           | Replacement PCB kit for FX-PDD             | 1.0 (0.5)          |



imagination at work