

Publication

GSA-CC1 Single Input Signal Module Installation Sheet
P/N P-047550-1802-EN • REV 04 • ISS 23JUN15

Instructions

This page is the *print specification* for the publication. It is not part of the artwork for the publication and must be removed before production. Do not print this page.

Work with the factory manufacturing engineer to determine the best materials and methods to produce, bind, and package the publication. The manufacturing engineer will indicate when single-language editions of a publication should be combined into one print package.

General requirements

The printed publication must meet the following requirements unless otherwise stated in the “Specific requirements” section.

Design and production

Artwork is provided as a single-language PDF file of ordered pages at 100% scale. You can photoreduce or imposition artwork page images as needed.

When designing the print package, observe the following requirements:

- Imposition must preserve the intended reading sequence of the pages given in the artwork file.
- Multiple-language packages must present English first, and the remaining languages in ascending part number order.
- After folding, the publication part number should be clearly visible without unfolding.
- No cropping of the artwork is allowed. Information in the headers and footers must be retained.
- Binding gutters established in the artwork (such as for three-ring binding) must be observed.

Color

Unless otherwise specified, all printing is in CMYK black. Spot colors and RGB colors found in the artwork should be converted to CMYK black by the print vendor.

Legibility

To ensure legibility and usability, we specify the following limits for the final print product:

- Photoreduction of the artwork must result in a minimum effective font size of 6 pt. for body text.
- The paper stock and ink used must result in a minimum effective opacity of 85%.
- Photoreduction and printing methods must result in a minimum resolution of 300 dpi, and all illustration and callout lines must be visible and unbroken.

Specific requirements

None



GSA-CC1 Single Input Signal Module Installation Sheet

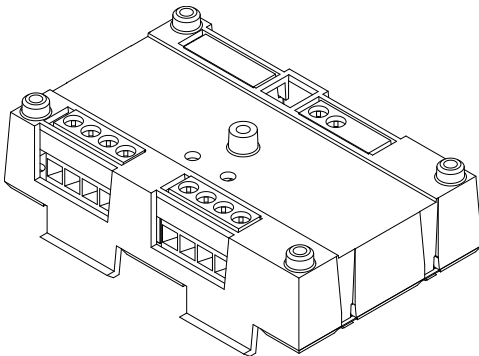

Description

The GSA-CC1 Single Input Signal Module is an addressable module that is used to connect the following circuits:

- Audible and visible notification appliance circuits (synchronized or unsynchronized)
- Speaker circuits
- Two-way telephone communication circuits (three-state or four-state)

Upon command from the loop controller, the module connects supervised Class B signal or telephone circuits to the respective riser input. The riser input can be 24 VDC (to operate polarized audible and visible signal notification appliances), 25 or 70 VRMS (to operate audio evacuation speakers), or firefighter telephones.

The module does not provide signal synchronization. To meet UL 864 requirements for horn and strobe signal synchronization, you must install a Genesis Signal Master module.

The GSA-CC1 module requires one address on the signaling line circuit (SLC). Addresses are assigned electronically. There are no address switches.

Diagnostic LEDs provide visible indication of the state of the module through the cover plate:

- Normal: Green LED flashes
- Alarm/active: Red LED flashes

Personality codes

The module requires the loop controller to download the personality code that determines how the module operates. Use the personality codes described below to configure the GSA-CC1. See Table 1 for listing information.

Table 1: Personality code listing information

Code	Description	UL 864	CAN/ULC-S527
5	Signal - supervised output (Class B)	Yes	Yes
6	Telephone - three-state (Class B)	No	No
26	Telephone - four-state (Class B)	Yes	Yes

Personality code 5: Signal - supervised output (Class B). Configures the GSA-CC1 module as a riser selector for audible and visible notification appliance circuits or for single-channel audio circuits. The output circuit is monitored for open or shorted wiring. If a short exists, the module will not activate in order to prevent shorting the riser. The module will activate once the short is cleared.

Personality code 6: Telephone - three-state (Class B) Configures the module as a riser selector for a three-state firefighter telephone. When a telephone handset is plugged into its jack or lifted from its hook, the module generates its own ring-tone signal, making a separate ring-tone riser unnecessary. The module sends this signal to the control panel to indicate the presence of an off-hook condition, and waits for the system operator to respond to the call. When the system operator responds, the ring-tone signal is disabled.

Personality code 26: Telephone - four-state (Class B). Configures the module as a riser selector for a four-state firefighter telephone. Operation is the same as Personality code 6 except that the module can distinguish when a telephone is off-hook and when the circuit is shorted, which causes a trouble condition.

Installation

Notes

- The module is shipped from the factory as an assembled unit; it contains no user-serviceable parts and should not be disassembled.
- This module does not operate without electrical power. As fires frequently cause power interruption, discuss further safeguards with the local fire protection specialist.

Install in accordance with all applicable local codes and standards and the local authority having jurisdiction.

To install the module:

1. Wire in accordance with “Wiring” below.
2. Write the address assigned to the module on the label provided, and then apply the label to the module. Remove the serial number label from the detector and, and then attach it to the project documentation.
3. Using the screw provided, mount the wall plate on the module. See Figure 1 for mounting details.
4. Using the screws provided, mount the wall plate (with the module attached) on one of the compatible electrical boxes listed in “Specifications” on page 6.

Figure 1: Mounting the GSA-CC1 module

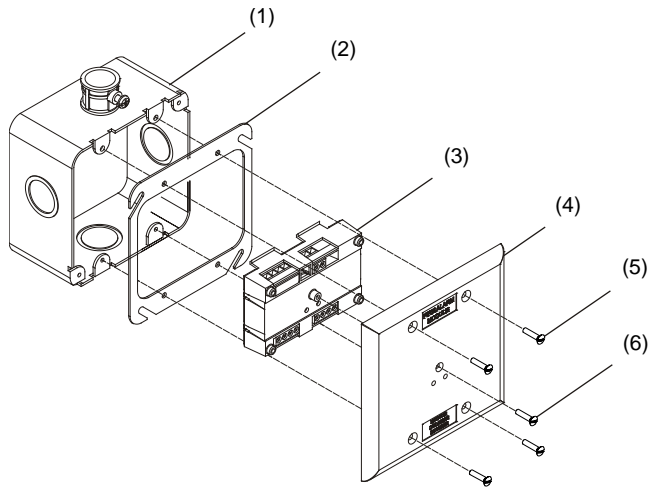

- | | |
|-------------------------------------|---------------------------------|
| (1) Compatible electrical box | (4) Wall plate, (dual-gang) |
| (2) 2-gang ring cover (if required) | (5) #6-32 x 5/8 screw (4X) |
| (3) Module | (6) #4 x 1/2 self-tapping screw |

Protection from transient spikes

For installations in which the output circuit connects to electromechanical bells or horns, install a Bipolar Transient Protector (P/N 235196P) to prevent inductive loads from causing transient spikes.

To install a bipolar transient protector:

1. Install the transient protector on the output of the module. Fit the transient protector into the electrical box with the module. See Figure 2.

Figure 2: Bell circuit showing bipolar transient protector placement

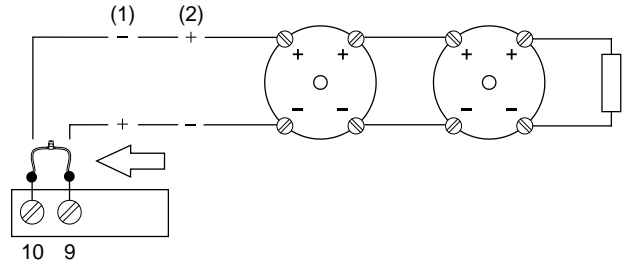

1. Normal state
2. Active state

Wiring

Wire in accordance with applicable requirements of the latest editions of the local codes and standards and the local authority having jurisdiction.

Strip 1/4 in. (about 6 mm) from the ends of all wires that connect to the terminal block of the module.

Note: When stripping wire ends, exposing more wire may cause a ground fault; exposing less wire may result in a faulty connection.

General wiring notes

- Refer to the Signature loop controller installation sheet for SLC wiring specifications. Refer to the firefighter phone installation sheet for additional details.
- Each terminal on the module is limited to a single conductor.
- Test resistors are supplied with the GSA-CC1 to prevent trouble signals on unused circuits during installation. When connecting field wires, remove the test resistors and install a UL/ULC Listed 47 kΩ EOLR at the end of the circuit.
- The module does not support conventional smoke detectors.

Riser notes

- For maximum line impedance, refer to the installation manual for the fire alarm panel. Maximum circuit capacitance is 0.1 μF.
- If the riser is used for more than one notification zone, install in accordance with the survivability from attack by fire requirements in NFPA 72 *National Fire Alarm and Signaling Code*.
- Circuit and riser wiring is different when four-state firefighter telephones are installed on three-state circuits. Before replacing a GSA-CC1 module, tag the wires to ensure correct reconnection.
- The GSA-CC1 module does not supervise the riser; the fire alarm control panel provides this function.

To wire the module:

1. Verify that all field wiring is free of opens, shorts, and ground faults.
2. Make all the connections as shown in Figure 3 through Figure 5.

Figure 3: Wiring diagram for NAC (personality code 5)

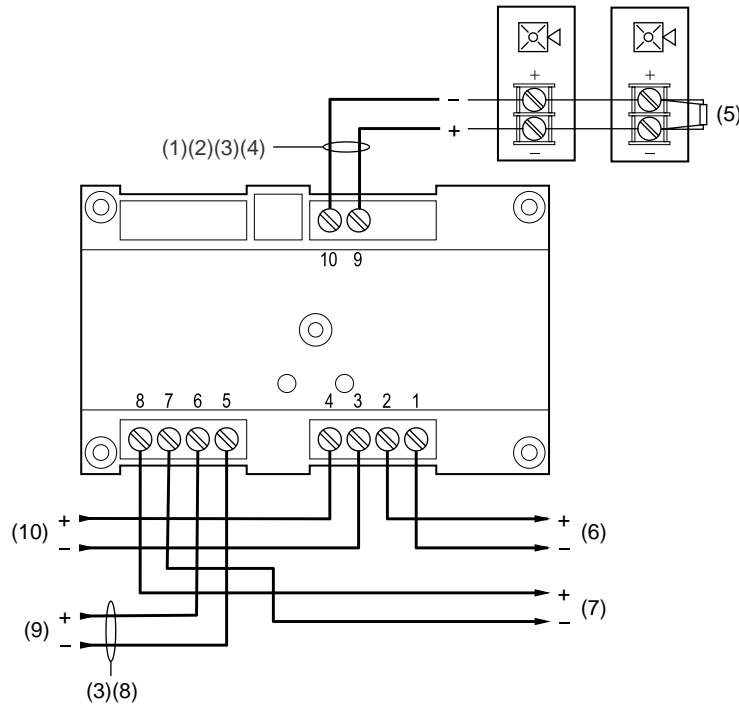

- | | |
|---|---|
| <p>(1) Signal polarity is shown when the circuit is in supervisory state. Polarity reverses when the circuit is active.</p> <p>(2) Supervised.</p> <p>(3) Power-limited unless connected to a nonpower-limited source. If the source is nonpower-limited, eliminate the power-limited mark and maintain a minimum of 0.25 in. (6.4 mm) space from power-limited wiring. For other mounting methods, see enclosure and bracket installation sheets to maintain separation of power-limited and nonpower-limited wiring. The wire size must be capable of handling fault current from nonpower-limited source.</p> <p>— or —</p> <p>Use type FPL, FPLR, FPLP, or permitted substitute cables, provided these power-limited cable conductors extending beyond the jacket are separated by a minimum of 0.25 in. (6.4 mm) space or by a nonconductive sleeve or nonconductive barrier from all other conductors. Refer to the NFPA 70 <i>National Electrical Code</i> for more details.</p> | <p>(4) If using a G1-P Genesis series horn while connected to a compatible fire alarm control panel, a CDR-3 Bell Coder must be used to comply with ANSI S3.41.</p> <p>(5) 47 kΩ EOLR.</p> <p>(6) Signaling line circuit (SLC) to next device.</p> <p>(7) AUX riser (to next module or riser supervisory device).</p> <p>(8) Power-limited regulated, power supply UL/ULC Listed for fire protective signaling systems.</p> <p>(9) AUX riser (from previous device).</p> <p>(10) Signaling line circuit (SLC) from previous device. Supervised and power-limited.</p> |
|---|---|

Figure 4: Wiring diagram for audio (personality code 5)

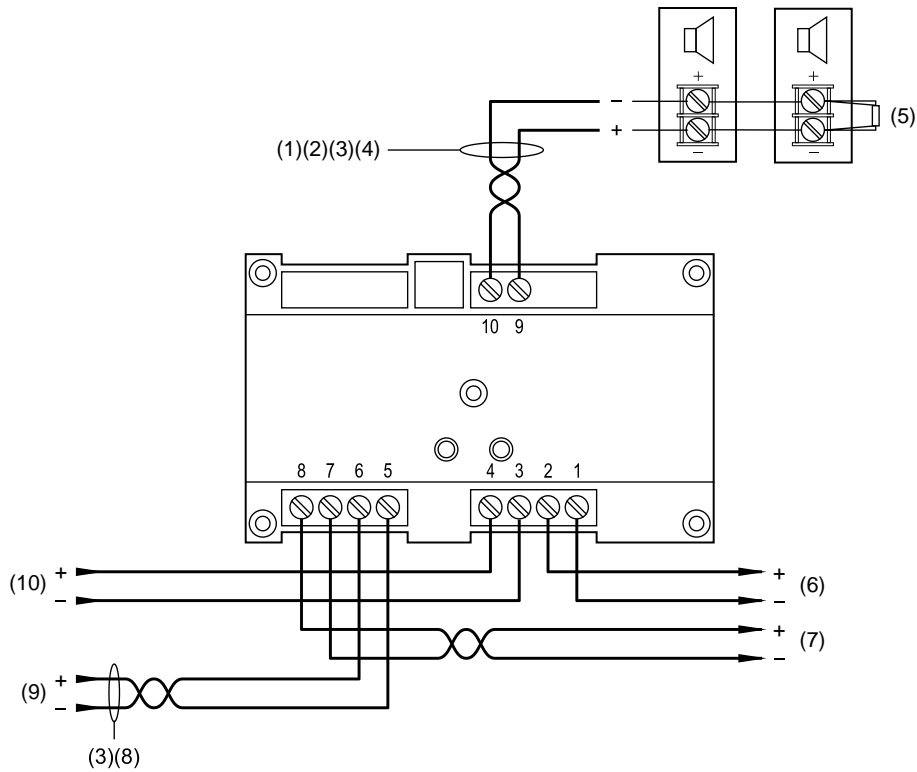

- | | |
|--|--|
| <p>(1) Signal polarity shown when the circuit is in supervisory state. Polarity reverses when the circuit is active.</p> <p>(2) Supervised.</p> <p>(3) Power-limited unless connected to a nonpower-limited source. If the source is nonpower-limited, eliminate the power-limited mark and maintain a minimum of 0.25 in. (6.4 mm) space from power-limited wiring. For other mounting methods, see enclosure and bracket installation sheets to maintain separation of power-limited and nonpower-limited wiring. The wire size must be capable of handling fault current from nonpower-limited source.</p> <p>— or —</p> <p>Use type FPL, FPLR, FPLP, or permitted substitute cables, provided these power-limited cable conductors extending beyond the jacket are separated by a minimum of 0.25 in. (6.4 mm) space or by a nonconductive sleeve or nonconductive barrier from all other conductors. Refer to the NFPA 70 <i>National Electrical Code</i> for more details.</p> | <p>(4) Unshielded twisted pair.</p> <p>(5) 47 kΩ EOLR (P/N EOL-47).</p> <p>(6) Signaling line circuit (SLC) to next device.</p> <p>(7) Audio riser (to next module or supervisory end of line device).</p> <p>(8) Unshielded twisted pair. Use shielded twisted pair when installed in the same conduit as with a telephone riser.</p> <p>(9) Audio riser (from previous device).</p> <p>(10) Signaling line circuit (SLC) from previous device. Supervised and power-limited.</p> |
|--|--|

Figure 5: Class B telephone (personality codes 6 and 26)

Three-state telephone circuit (personality code 6)

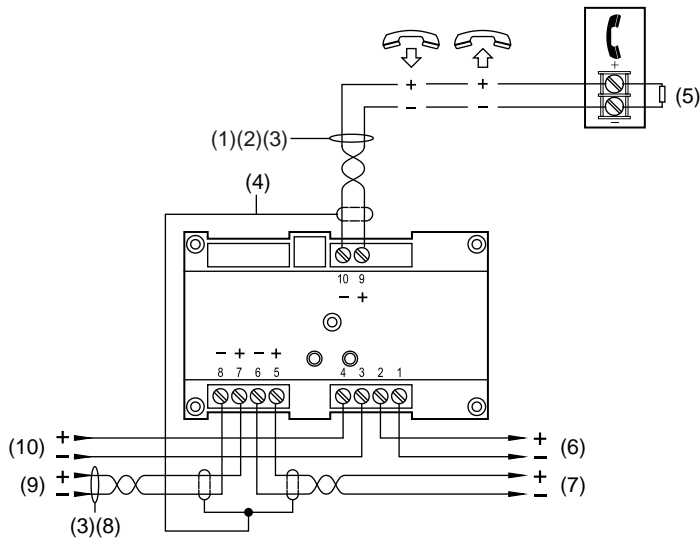

Four-state telephone circuit (personality code 26)

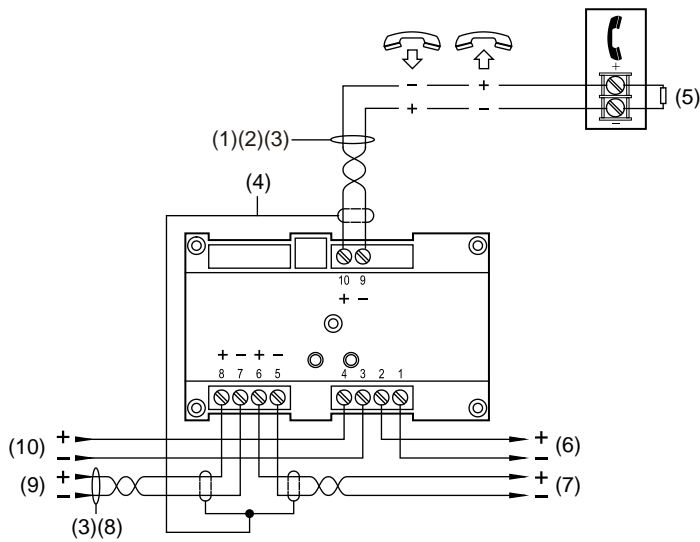

- (1) Telephone circuit. The plus and minus symbols indicate signal polarity.
- (2) Supervised.
- (3) Power-limited unless connected to a nonpower-limited source. If the source is nonpower-limited, eliminate the power-limited mark and maintain a minimum of 0.25 in. (6.4 mm) space from power-limited wiring. For other mounting methods, see enclosure and bracket installation sheets to maintain separation of power-limited and nonpower-limited wiring. The wire size must be capable of handling fault current from nonpower-limited source.
— or —
Use type FPL, FPLR, FPLP, or permitted substitute cables, provided these power-limited cable conductors extending beyond the jacket are separated by a minimum of 0.25 in. (6.4 mm) space or by a nonconductive sleeve or nonconductive barrier from all other conductors. Refer to the NFPA 70 *National Electrical Code* for more details.
- (4) Required if the distance from the GSA-CC1 to the phone is greater than 5 ft. Shield must be continuous, insulated, and isolated from ground, except for the connection to chassis ground in the control panel.
- (5) 47 kΩ EOLR (P/N EOL-47).
- (6) Signaling line circuit (SLC) to next device.
- (7) Telephone riser (to next module or end-of-line supervisory device).
- (8) Use shielded twisted pair. Shields must be continuous and grounded at the panel end.
- (9) Telephone riser (from previous device).
- (10) Signaling line circuit (SLC) from previous device. Supervised and power-limited.

Specifications

Operating voltage range	15.20 to 19.95 VDC
Current	
Standby	310 μ A
Activated	135 μ A
Maximum line impedance	Refer to the control panel installation manual
Ground fault impedance	10 k Ω
Output ratings (special applications)	
24 VDC	2 A
25 VRMS audio	50 W
70 VRMS audio	35 W
EOL resistor value	47 k Ω
Circuit resistance	Refer to the control panel installation manual
Circuit capacitance	0.1 μ F max.
EOLR	47 k Ω (P/N EOL-47)
Circuit designation	
Signaling line circuits	Class A, Style 6 or Class B, Style 4
Telephone riser circuits	Class B, Style 4
Notification line circuits	Class B, Style Y
Compatible electrical boxes	2-1/2 in. (64 mm) deep dual-gang box; 4 in. square box 1-1/2 in. (38 mm) deep box with a dual-gang cover
Wire sizes	12 to 18 AWG wire (0.75 to 2.5 mm ²)
Operating environment	
Temperature	32 to 120°F (0 to 49°C)
Relative humidity	0 to 93%, noncondensing
Storage temperature range	-4 to 140°F (-20 to 60°C)

Regulatory information

Manufacturer	Edwards, A Division of UTC Fire & Security Americas Corporation, Inc. 8985 Town Center Parkway, Bradenton, FL 34202, USA
Year of manufacture	The first two digits of the DATE MFG number (located on the product identification label) are the year of manufacture.
FCC compliance	This device complies with part 15 of the FCC Rules. Operation is subject to the following two conditions: (1) This device may not cause harmful interference, and (2) this device must accept any interference received, including interference that may cause undesired operation.
North American standards	CAN/ULC-S527, UL 864

Contact information

For contact information, see www.utcfireandsecurity.com.