

DO-200VF

DEF-teck



Características principales

- La Cámara más Inteligente y profesional del mercado
- Exterior, Certificación IP67
- Resolución Full HD 1080P
- Alimentación POE
- IR inteligentes
- Audio In/Out
- DI/DO
- Compresión H.264
- WDR (Wyde Dynamic Range)
- Filtro ICR
- ONVIF

ONVIF

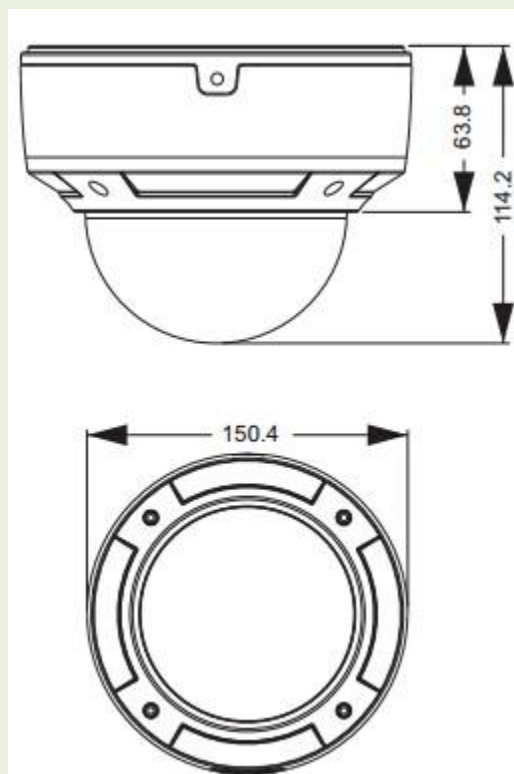

DO-200VF

DO-200VF	
Camera	
Image Sensor	Sensor Sony Cmos 1/3"
Resolución	2MP: 1920 x 1080
Electronic Shutter	1/25s - 1/100.000
Auto Iris	YES
Min. Illumination	0 Lux (IR Led ON)
Lens	2.8 ~ 12mm
Image	
Compression	H.264/MJPEG
Multi-Stream	YES
FPS	30
WDR	YES
Noise Reduction	YES
Port	
Network	RJ45
Functions	
Remote Monitoring	IE Browsing, CMS Remote Control
Protocol	TCP/IP, UDP, DHCP, NTP, RTSP, PPPoE, DDNS, SMTP, FTP
Connection Protocol	ONVIF, GB-T/28181-2011
Storage	Internet Remote Storage
Smart Alarm	Motion alarm
Day & Night	ICR
Digital PTZ	YES
POE	YES 802.3af
IR Distance	30 Mts.
Water-Proof	IP67
General	
Power Supply	DC 12V/ POE 802.3af
Working Enviroment	- 40°c ~ 50°c