



# K-R Series Remote Annunciator Installation and Operation Guide

**Copyright** © 2016 United Technologies Corporation. All rights reserved.

This document may not be copied in whole or in part or otherwise reproduced without prior written consent from United Technologies Corporation, except where specifically permitted under US and international copyright law.

**Trademarks and patents** The K-R Series Remote Annunciator name and logo are trademarks of United Technologies Corporation

Other trade names used in this document may be trademarks or registered trademarks of the manufacturers or vendors of the respective products.

**Version** This document applies to K-R Series Remote Annunciator version 2.04.00 and above.

**FCC compliance** This equipment has been tested and found to comply with the limits for a Class A digital device, pursuant to part 15 of the FCC Rules. These limits are designed to provide reasonable protection against harmful interference when the equipment is operated in a commercial environment. This equipment generates, uses, and can radiate radio frequency energy and, if not installed and used in accordance with the instruction manual, may cause harmful interference to radio communications. Operation of this equipment in a residential area is likely to cause harmful interference in which case the user will be required to correct the interference at his own expense.



2006/66/EC (battery directive): This product contains a battery that cannot be disposed of as unsorted municipal waste in the European Union. See the product documentation for specific battery information. The battery is marked with this symbol, which may include lettering to indicate cadmium (Cd), lead (Pb), or mercury (Hg). For proper recycling, return the battery to your supplier or to a designated collection point. For more information see: [www.recyclethis.info](http://www.recyclethis.info).

**Contact information** For contact information, see [www.kiddelivesafety.com](http://www.kiddelivesafety.com).

# Content

<b>Important information</b>	<b>ii</b>
Limitation of liability	ii
Advisory messages	ii
<b>Introduction to the K-R Series</b>	<b>1</b>
<b>Installation terminals and controls</b>	<b>4</b>
<b>Installing annunciators and expanders</b>	<b>6</b>
<b>Wiring diagrams</b>	<b>8</b>
<b>Troubleshooting</b>	<b>10</b>
<b>Specifications</b>	<b>11</b>
<b>Operating the LCD models</b>	<b>12</b>
<b>Operating the LED models</b>	<b>14</b>
<b>Reading LCD displays</b>	<b>16</b>
System Normal screen	16
Event Message screen	16
Details screen	17
<b>Entering a password</b>	<b>18</b>
<b>Message priorities</b>	<b>19</b>

# Important information

## Limitation of liability

To the maximum extent permitted by applicable law, in no event will United Technologies Corporation be liable for any lost profits or business opportunities, loss of use, business interruption, loss of data, or any other indirect, special, incidental, or consequential damages under any theory of liability, whether based in contract, tort, negligence, product liability, or otherwise. Because some jurisdictions do not allow the exclusion or limitation of liability for consequential or incidental damages the preceding limitation may not apply to you. In any event the total liability of United Technologies Corporation shall not exceed the purchase price of the product. The foregoing limitation will apply to the maximum extent permitted by applicable law, regardless of whether United Technologies Corporation has been advised of the possibility of such damages and regardless of whether any remedy fails of its essential purpose.

Installation in accordance with this manual, applicable codes, and the instructions of the authority having jurisdiction is mandatory.

While every precaution has been taken during the preparation of this manual to ensure the accuracy of its contents, United Technologies Corporation assumes no responsibility for errors or omissions.

## Advisory messages

Advisory messages alert you to conditions or practices that can cause unwanted results. The advisory messages used in this document are shown and described below.

---

**WARNING:** Warning messages advise you of hazards that could result in injury or loss of life. They tell you which actions to take or to avoid in order to prevent the injury or loss of life.

---

**Caution:** Caution messages advise you of possible equipment damage. They tell you which actions to take or to avoid in order to prevent the damage.

---

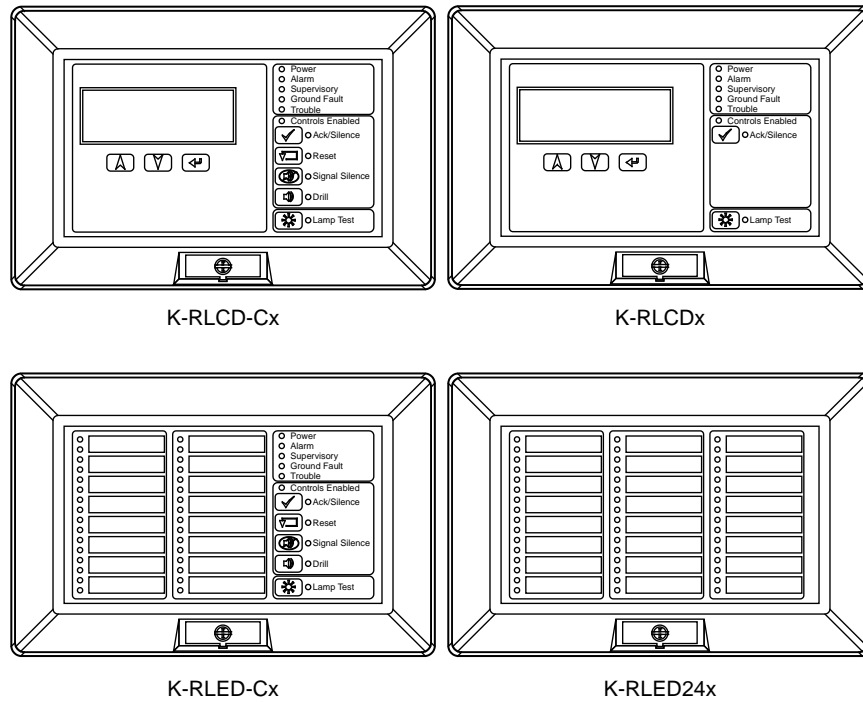
**Note:** Note messages advise you of the possible loss of time or effort. They describe how to avoid the loss. Notes are also used to point out important information that you should read.

# Introduction to the K-R Series

The K-R Series Remote Annunciator provide remote annunciation for fire and emergency alarm systems. The annunciators offer LCD or LED annunciation, and can include common controls. The expander uses LEDs.

The K-R Series includes three annunciator models and one expander model. One or two expanders can be connected to any of the annunciator models. Figure 1 shows the four models in the K-R Series. Table 1 lists the features of each model. Table 2 is a complete list of all models and accessories in the series.

**Figure 1: Models in the K-R Series**



**Table 1: Features of the models**

Model	LCD Display	Zone LEDs	Common controls	System LEDs	Buzzer
K-RLCD, K-RLCDF, K-RLCD-R, K-RLCD-PG, K-RLCD-SP	Yes	No	No	Yes	Yes
K-RLCD-C, K-RLCD-CF, K-RLCD-CR, K-RLCD-C-PG, K-RLCD-C-SP	Yes	No	Yes	Yes	Yes
K-RLED-C, K-RLED-CF, K-RLED-CR, K-RLED-C-PG, K-RLED-C-SP	No	16 pairs	Yes	Yes	Yes
K-RLED24, K-RLED24R	No	24 pairs	No	No	No

The annunciators and expanders can be mounted on a standard 4 in. square electrical box, using the included mounting ring. They can also be surface mounted in locking steel enclosures.

The annunciators communicate with the FACP on the RS-485 data riser. This can be configured for Class A or Class B communication. The annunciators do not provide ground fault isolation.

The annunciators are stand-alone units that can be powered by the FACP or by an approved power supply.

Models with common controls can use a separate, remote key switch to enable or disable the common controls.

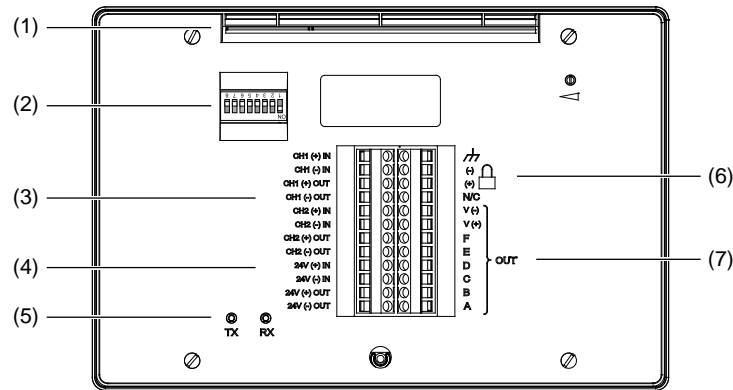
**Table 2: K-R Series models and accessories**

<b>Model number</b>	<b>Description</b>
K-RLCD	Remote Annunciator: LCD text annunciator without common controls. English.
K-RLCDF	Remote Annunciator: LCD text annunciator without common controls. French.
K-RLCD-R	Remote Annunciator: LCD text annunciator without common controls. English. Red.
K-RLCD-PG	Remote Annunciator: LCD text annunciator without common controls. Portuguese.
K-RLCD-SP	Remote Annunciator: LCD text annunciator without common controls. Spanish.
K-RLCD-C	Remote Annunciator: LCD text annunciator with common controls. English.
K-RLCD-CF	Remote Annunciator: LCD text annunciator with common controls. French.
K-RLCD-CR	Remote Annunciator: LCD text annunciator with common controls. English. Red.
K-RLCD-C-PG	Remote Annunciator: LCD text annunciator with common controls. Portuguese.
K-RLCD-C-SP	Remote Annunciator: LCD text annunciator with common controls. Spanish.
K-RLED-C	Remote Annunciator: 16-pair LED zone annunciator with common controls. English.
K-RLED-CF	Remote Annunciator: 16-pair LED zone annunciator with common controls. French.
K-RLED-CR	Remote Annunciator: 16-pair LED zone annunciator with common controls. English. Red.
K-RLED-C-PG	Remote Annunciator: 16-pair LED zone annunciator with common controls. Portuguese.
K-RLED-C-SP	Remote Annunciator: 16-pair LED zone annunciator with common controls. Spanish.
K-RLED24	Remote Expander: 24-pair LED zone expander with expander cable and zone card insert.
K-RLED24R	Remote Expander: 24-pair LED zone expander with expander cable and zone card insert. Red.
RA-ENC1	One-position enclosure for Remote Annunciator.
RA-ENC2	Two-position enclosure for Remote Annunciator and one Remote Expander, including one interconnection cable.
RA-ENC3	Three-position enclosure for Remote Annunciator and two Remote Expanders, including two interconnection cables.
RKEY	Remote key switch on plate for enabling or disabling common controls (Lock/Unlock).
RA-LED16ZC	Zone card insert for K-RLED-C, K-RLED-CR, and K-RLED-CF.
RA-LED24ZC	Zone card insert for K-RLED24, K-RLED24R.

<b>Model number</b>	<b>Description</b>
27193-16	Electrical box, surface mount, white, single-gang.
7300073	24-inch expander cable assembly, includes cable and hardware.
7120313-01	12-inch expander cable (cable only).
7120313-02	24-inch expander cable (cable only).

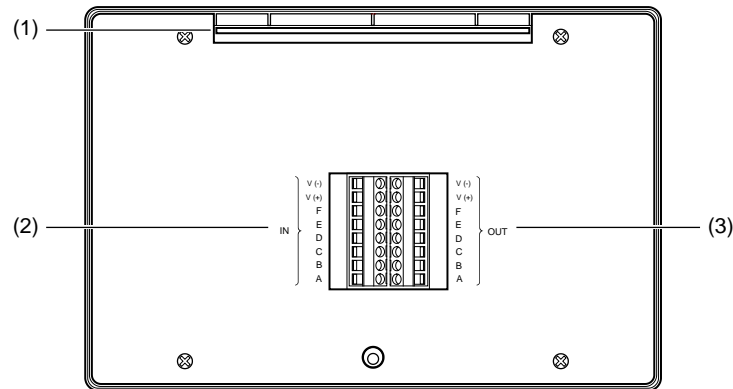
# Installation terminals and controls

**Figure 2: Annunciator rear view showing terminals and controls**



- (1) Mounting slot
- (2) DIP switch
- (3) Annunciator bus IN/OUT terminals
- (4) Power riser IN/OUT terminals
- (5) Transmit and receive communication LEDs
- (6) Remote key switch terminals
- (7) Expander cable terminals

**Figure 3: Expander rear view showing terminals**



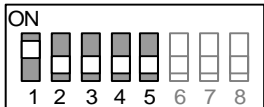
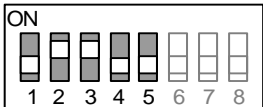
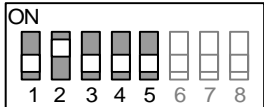
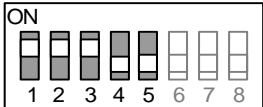
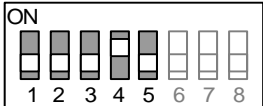
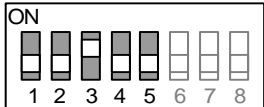
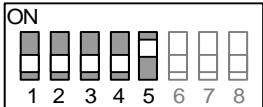
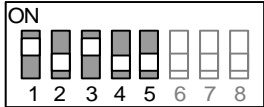

- (1) Mounting slot
- (2) Expander cable IN terminals
- (3) Expander cable OUT terminals



**Table 3: DIP switch settings**

Switch	Description
S1 to S5	Annunciator address. The annunciator address (in binary). The factory setting is for address 2. See Table 4 for examples. Possible values: 1 to 31.
S6	Baud rate. OFF = 9600 baud (factory default setting) ON = All other baud rates
S7	Annunciator circuit type. OFF = Circuit supports Class B and Redundant Class B wiring ON = Circuit supports Class B and Class A wiring
S8	Not used.

**Table 4: Examples of DIP switch address settings**

Address	Setting	Address	Setting
1		6	
2		7	
3		8	
4		16	
5		31	

# Installing annunciators and expanders

For correct operation, the annunciator must be configured with a unique address, must have the correct baud rate setting, and must be in communication with the FACP.

If you are installing a Remote Annunciator and Remote Expanders into RA-ENC2 or RA-ENC3 enclosures, you must install the expanders first. Refer to the installation sheets for the enclosures for the correct sequence of steps.

If you are installing Remote Annunciators and Remote Expanders using separate electrical boxes, the wire runs between the boxes must be enclosed in conduit.

If you are installing a remote key switch, the switch must be located within the enclosure or within 3 ft. (0.9 m) of the enclosure with the cabling installed in conduit or equivalent protection against mechanical injury.

## To install an annunciator:

1. Secure the mounting ring to the electrical box, as shown in Figure 4.
2. Use the DIP switch to set the correct address and baud rate. See Table 3 on page 5 for DIP switch settings.
3. Connect the control panel annunciator circuit to the appropriate annunciator terminals. See Figure 5, Figure 6, Figure 7, and Figure 8.

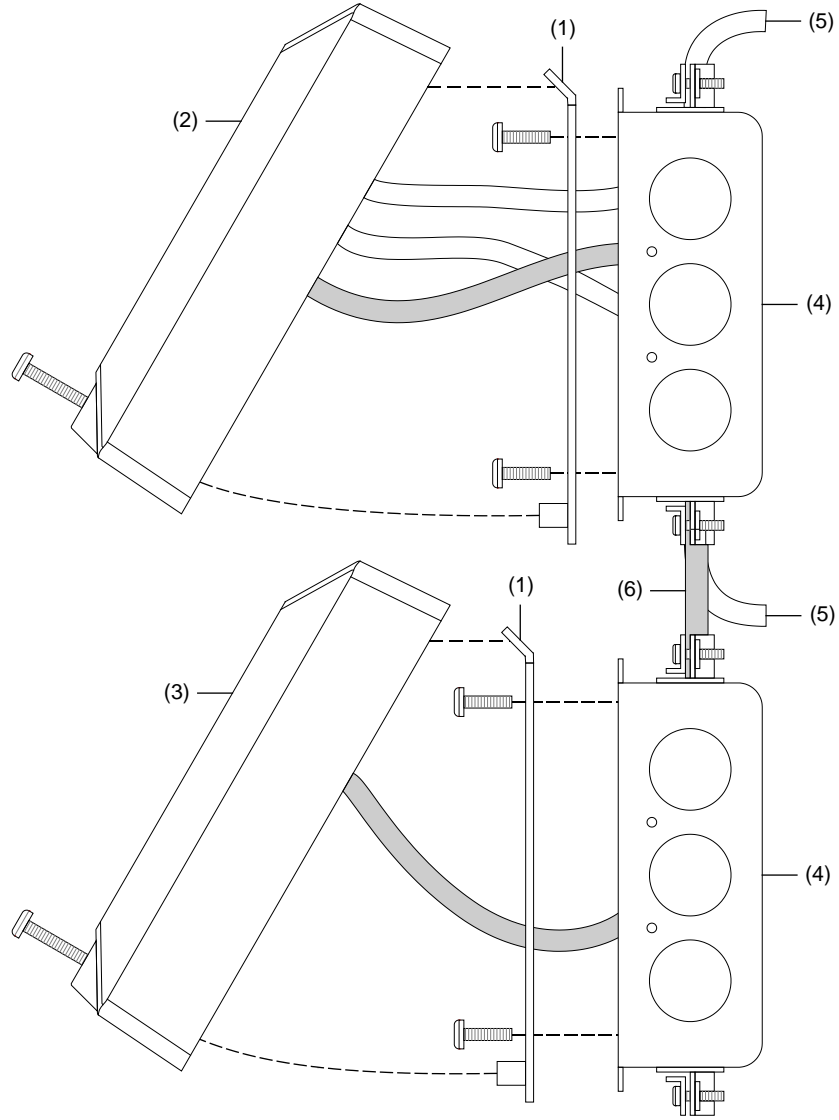
**Tip:** Leave enough wire to remove and position the annunciator when setting the DIP switch.

4. Attach the expander cable to the annunciator, if applicable. See Figure 9.
5. Attach the remote key switch wiring to the annunciator, if applicable. See Figure 8.
6. Tilt the annunciator up and slide the mounting slot onto the top flange of the mounting ring, as shown in Figure 4.
7. Tilt the annunciator down and push the bottom of the annunciator over the stud-nut.
8. Secure the bottom of the annunciator to the mounting ring using the captive screw.
9. Cover the screw hole with the product label plate.

## To install an expander:

1. Complete and insert the zone card (labeling sheet) into the expander.
2. Secure the mounting ring to the electrical box, as shown in Figure 4.
3. Connect the expander cable to the expander. Attach an expander cable for interconnection to a second expander, if applicable. See Figure 9.
4. Tilt the expander up and slide the mounting slot onto the top flange of the mounting ring, as shown in Figure 4.
5. Tilt the expander down and push the bottom of the expander over the stud-nut.
6. Secure the bottom of the expander to the mounting ring using the captive screw.
7. Cover the screw hole with the product label plate.
8. Repeat steps 1 through 7 for a second expander, if applicable.

**Figure 4: Installing the mounting ring, annunciator, and expander**



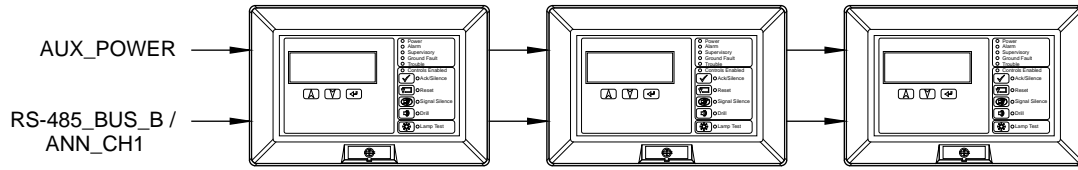
- (1) Mounting ring
- (2) Annunciator
- (3) Expander

- (4) Electrical box
- (5) RS-485 riser
- (6) Expander cable

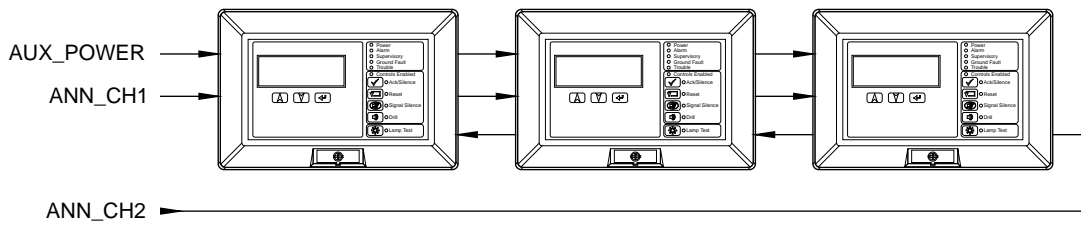
# Wiring diagrams

All wiring is supervised and power-limited, unless otherwise noted. For terminal connections, refer to the documents listed on the control panel label.

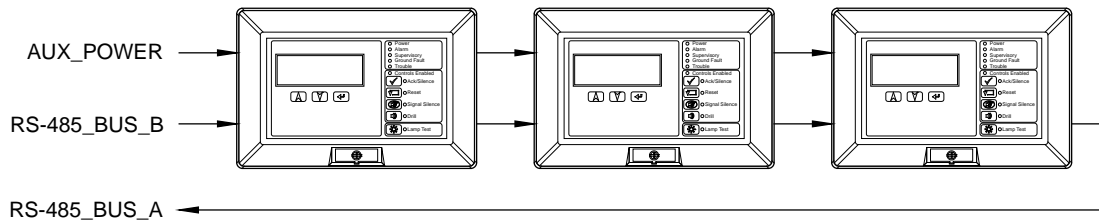
**Figure 5: Typical Class B wiring**



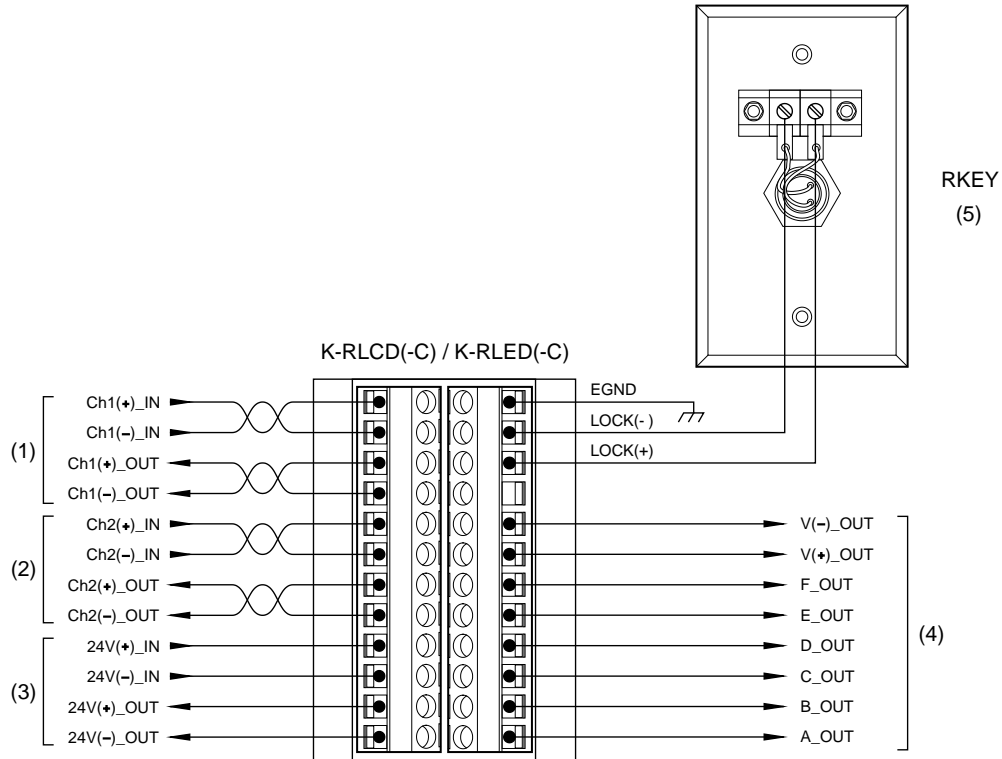
**Figure 6: Typical redundant Class B wiring**



**Figure 7: Typical Class A wiring**

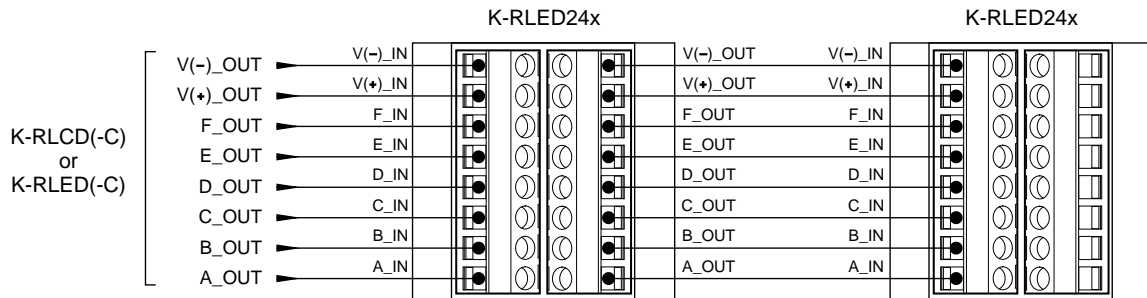


**Figure 8: Typical annunciator wiring**



- (1) CH1\_IN+/- from the control panel or previous annunciator. CH1\_OUT+/- to the next annunciator or to the control panel if the last annunciator on a Class A circuit.
- (2) CH2\_IN+/- from the control panel or previous annunciator. CH2\_OUT+/- to the next annunciator. Used only on redundant Class B circuits. See Figure 6 on page 8.
- (3) Use the control panel power supply or a 24 VDC, continuous, regulated, power supply that is UL/ULC Listed for fire protective signaling systems.
- (4) To the expander. See Figure 9.
- (5) The remote key switch wiring is not supervised. The key switch must be located within 3 ft. (0.9 m) of the annunciator and installed in conduit, or equivalent protection against mechanical injury. A remote key switch is required on K-RLED-C remote annunciators.

**Figure 9: Typical expander wiring**



# Troubleshooting

When a K-R Series annunciator is operating correctly, the Trouble LED follows the panel's Trouble LED. Annunciators with LCD displays show the same trouble messages as the panel. See the topic "Reading LCD displays" on page 16 for details about message displays.

The following table summarizes symptoms and solutions for common installation and operation problems.

**Table 5: K-R Series troubleshooting**

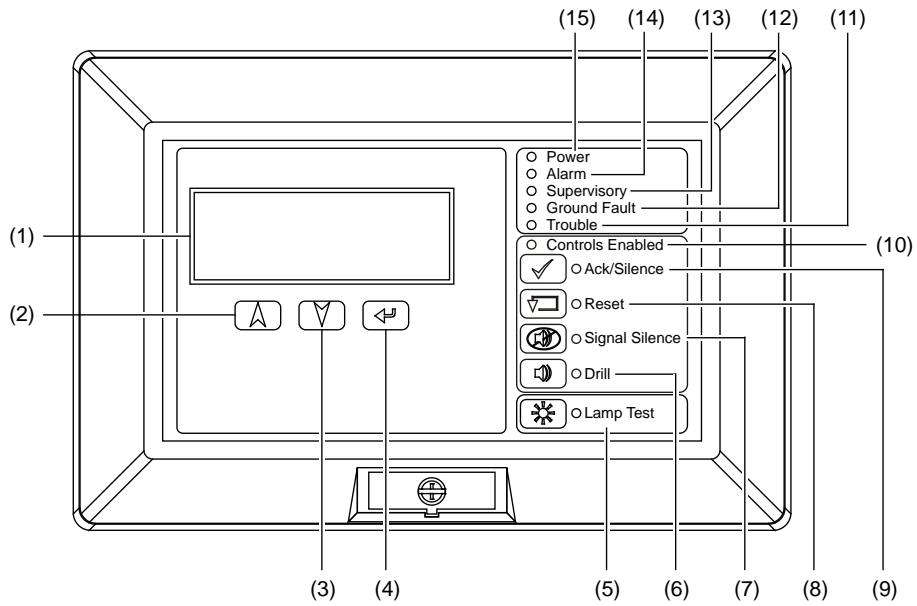
<b>Problem</b>	<b>Cause</b>
Panel detail display: Annunciator 000 Communication Fault	Communication wiring has an open fault Communication wiring polarity is reversed Annunciator has no power Annunciator address DIP switches are set incorrectly (on the annunciator shown in the panel message) Annunciator network baud rate DIP switch is set incorrectly (for normal operation use 9600 baud) Annunciator bus type DIP switch is set incorrectly (change S1-7 to the other position)
Annunciator LCD and LEDs are inoperative	Annunciator has no power
Annunciator control switches don't work	Remote key switch is in the "locked" or disabled position Password entry may be required (see "Entering a password" on page 18)
Lamp test	During a lamp test the annunciators with LCDs show the version of annunciator firmware currently loaded

# Specifications

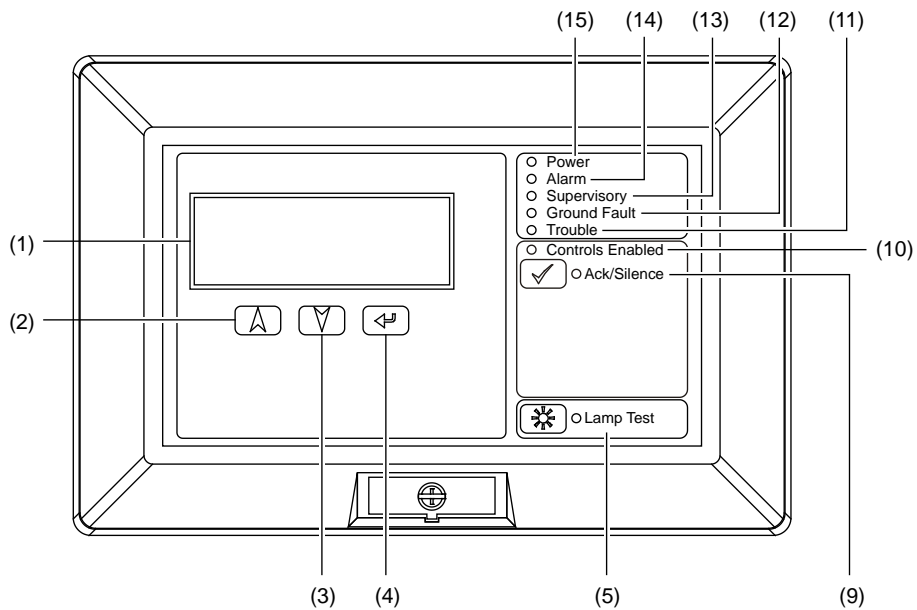
Voltage	24 VDC, continuous. Do not use control panel AUX power outputs that are interrupted when the panel is reset. Supply must be UL/ULC Listed for use with fire protective signaling systems and have a rating designation of Regulated 24 DC or Regulated 24 FWR.
Standby current	
K-RLCD, K-RLCDF, K-RLCD-R, K-RLCD-PG, K-RLCD-SP	98 mA
K-RLCD-C, K-RLCD-CF, K-RLCD-CR, K-RLCD-C-PG, K-RLCD-C-SP	99 mA
K-RLED-C, K-RLED-CF, K-RLED-CR, K-RLED-C-PG, K-RLED-C-SP	28 mA
K-RLED24, K-RLED24R	6 mA
Alarm current	
K-RLCD, K-RLCDF, K-RLCD-R, K-RLCD-PG, K-RLCD-SP	113 mA
K-RLCD-C, K-RLCD-CF, K-RLCD-CR, K-RLCD-C-PG, K-RLCD-C-SP	115 mA
K-RLED-C, K-RLED-CF, K-RLED-CR, K-RLED-C-PG, K-RLED-C-SP	62 mA
K-RLED24, K-RLED24R	34 mA
Annunciator circuit	
Class/Style	Class B, Redundant Class B, or Class A
Wire size	14 to 18 AWG (1.0 to 2.5 mm <sup>2</sup> )
Type	Twisted pair, 6 twists per ft. min.
Length	4,000 ft. (1,219 m), max.
Baud rate	9600 to 115200 baud
Remote key switch circuit	5 VDC at 1 mA, power-limited, unsupervised
Ground fault impedance	0 Ω
Power wiring	14 to 18 AWG (1.0 to 2.5 mm <sup>2</sup> )
Display area	4 lines of 20 characters each
Dimensions (H x W x D)	5-5/8 x 8-1/2 x 1-1/2 in. (14.3 x 21.4 x 3.8 cm)
Mounting	North American 4 in. square electrical box or listed enclosure (see Table 2)
Operating environment	
Temperature	32 to 120°F (0 to 49°C)
Relative humidity	0 to 93% noncondensing

# Operating the LCD models

**Figure 10: Controls and indicators for LCD remote annunciator models with common controls**



**Figure 11: Controls and indicators for LCD remote annunciator models without common controls)**





**Table 6: Controls and indicators for LCD remote annunciators (with and without common controls)**

No.	Item	Description
1	LCD display	Displays system status, event messages, and event message details.
2	Up cursor button	Scrolls up through the messages in the event message queue. Scrolls up through characters for password entry.
3	Down cursor button	Scrolls down through the messages in the event message queue. Scrolls down through characters for password entry.
4	Enter button	Displays message details for the current message. Enters the password character selected.
5	Lamp Test LED-button	Green LED that indicates the annunciator is energized.  Turns on all LEDs and displays a test pattern on the LCD. The test runs for ten seconds. The LED next to the button indicates the lamp test is running.
6	Drill LED-button	Turns on all audible and common alarm output devices and, if configured, all visible devices. Pressing the button again turns them back off. The LED next to the button indicates the function is active. Requires a password to operate.  <b>Note:</b> You must press and hold the button for 2 seconds to initiate a drill.
7	Signal Silence LED-button	Turns off (silences) all active audible and common alarm output devices and, if configured, all visible devices. Pressing the button again turns them back on. The LED next to the button indicates the function is active. Requires a password or the enable controls key to operate.
8	Reset LED-button	Restores the system to the normal state, provided that no inputs are latched in the active state. The LED next to the button indicates the reset function is active. Requires a password or the enable controls key to operate.
9	Ack/Silence LED-button	Silences the panel buzzer and acknowledges all current events. The LED next to the button indicates the function is active. Requires a password or the enable controls key to operate.  <b>Note:</b> The password requirement may be disabled based on your system configuration settings.
10	Controls Enabled LED	Blue LED that indicates the controls in that group are enabled at the annunciator. Enabling the controls requires a password or the enable controls key.
11	Trouble LED	Yellow LED that indicates an active trouble state (flashing = new trouble event, steady = all current trouble events have been acknowledged).
12	Ground Fault LED	Yellow LED that indicates a ground fault somewhere in the system.
13	Supervisory LED	Yellow LED that indicates an active supervisory state (flashing = new supervisory event, steady = all current supervisory events have been acknowledged).
14	Alarm LED	Red LED that indicates an active alarm state (flashing = new alarm event, steady = all current alarm events have been acknowledged).
15	Power LED	Green LED that indicates the annunciator is energized.

# Operating the LED models

Figure 12: Controls and indicators for LED remote annunciator models with common controls

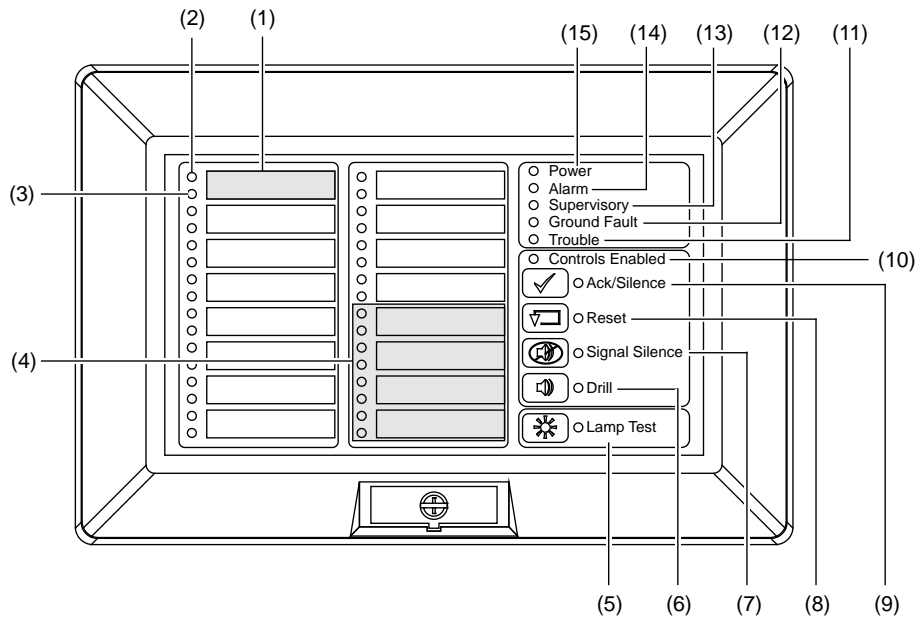
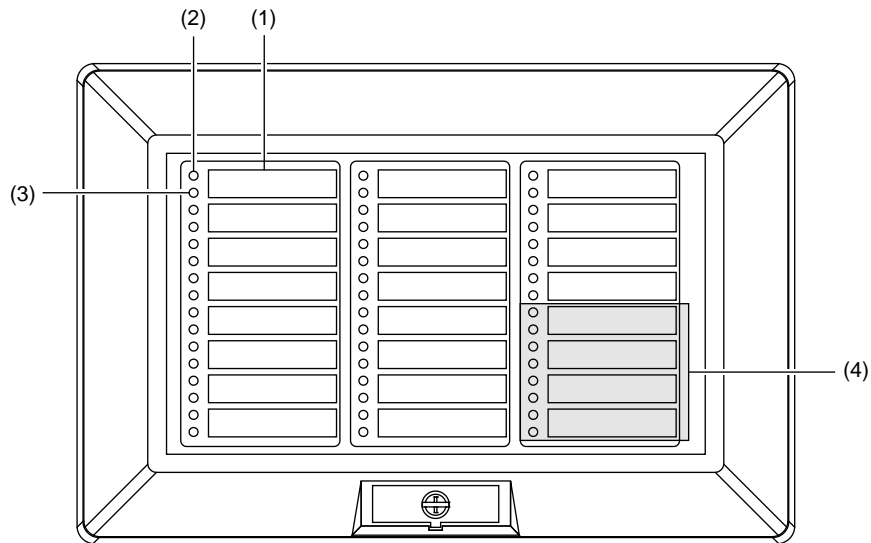


Figure 13: Controls and indicators for the K-RLED24 and K-RLED24R



**Table 7: Controls and indicators for LED remote annunciator models with common controls, K-RLED24, and K-RLED24R**

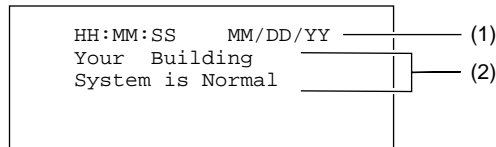
No.	Item	Description
1	Zone description label	Zone or device description.
2	Active LED	Red LED that indicates the zone or device is in the alarm state.
3	Trouble LED	Yellow LED that indicates the zone or device is in the trouble state.
4	Supervisory zones	The last four zones can be configured as alarm or supervisory. For these zones, the top LED is a red/yellow bicolor LED. Red = alarm event. Yellow = supervisory or monitor event.
5	Lamp Test LED-button	Turns on all LEDs and displays a test pattern on the LCD. The test runs for ten seconds. The LED next to the button indicates the lamp test is running.
6	Drill LED-button	Turns on all audible and common alarm output devices and, if configured, all visible devices. Pressing the button again turns them back off. The LED next to the button indicates the function is active. Requires a password to operate.  <b>Note:</b> You must press and hold the button for 2 seconds to initiate a drill.
7	Signal Silence LED-button	Turns off (silences) all active audible and common alarm output devices and, if configured, all visible devices. Pressing the button again turns them back on. The LED next to the button indicates the function is active. Requires a password or the enable controls key to operate.
8	Reset LED-button	Restores the system to the normal state, provided that no inputs are latched in the active state. The LED next to the button indicates the reset function is active. Requires a password or the enable controls key to operate.
9	Ack/Silence LED-button	Silences the panel buzzer and acknowledges all current events. The LED next to the button indicates the function is active. Requires a password or the enable controls key to operate.
10	Controls Enabled LED	Blue LED that indicates the controls in that group are enabled at the annunciator. Enabling the controls requires a password or the enable controls key.
11	Trouble LED	Yellow LED that indicates an active trouble state (flashing = new trouble event, steady = all current trouble events have been acknowledged).
12	Ground Fault LED	Yellow LED that indicates a ground fault somewhere in the system.
13	Supervisory LED	Yellow LED that indicates an active supervisory state (flashing = new supervisory event, steady = all current supervisory events have been acknowledged).
14	Alarm LED	Red LED that indicates an active alarm state (flashing = new alarm event, steady = all current alarm events have been acknowledged).
15	Power LED	Green LED that indicates the annunciator is energized.

# Reading LCD displays

In addition to the system status LEDs, two annunciator models include an LCD display that can show the system status, event messages, or event message details. The display can also be used to enter a password that enables the common control buttons.

## System Normal screen

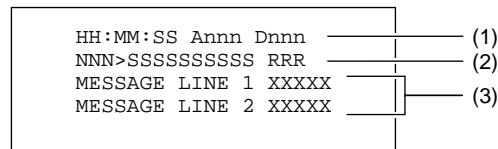
The LCD display shows the System Normal screen when the control panel is in the normal (quiescent) state.



- (1) Time and date: The system time in 24-hour format and the system date in MM/DD/YY or DD/MM/YY format, depending on the market place.
- (2) Banner lines: Your facility name (if programmed) and the message “System is Normal.”

## Event Message screen

The LCD display shows the Event Message screen when the control panel enters the alarm, supervisory, monitor, trouble, disablement, or test state. Use the Up and Down cursor buttons to scroll through the messages in the queue.



- (1) Time and points: The system time in 24-hour format, the number of active points (Annn), and the number of disabled points (Dnnn) currently in the system.
- (2) Event status: The event number (NNN), the event type (SSSSSSSSSS), and the event status (RRR). The event number is the position of the event in the queue. The event type is alarm, supervisory, trouble, or monitor. The event status is “Act” for active, or “Rst” for restored.

Note: The > symbol indicates the oldest, highest priority event. It is only visible when the K-R Series Remote Annunciator is connected to a VM-1 panel with C-CPU firmware version 1.40.00 and above, and the system is configured for the Canadian market.

- (3) Event message: The first and second lines of the event message.

## Example Event Message screen

```
13:47:00 A003 D000
001 ZONE ALARM ACT
East Wing Hallway
South Entrance
```

## Details screen

Pressing the Enter button while an event message is selected displays the Details screen. The system displays this screen as long as you are pressing the Enter button or using the Up and Down cursor buttons. The system returns to the Event Message screen after approximately 20 seconds of inactivity. You can also toggle between the Event Message and Details screens by pressing and releasing the Enter button.

```
DETAILS          v^ (1)
P:nn C:nn D:nnn (2)
DEVICE MESSAGE LINE1 (3)
DEVICE MESSAGE LINE2
```

- (1) Scrolling symbols: The symbols at the right of the screen title line show whether there are more detail messages before or after the current message. Use the Up and Down cursor buttons to scroll through the detail messages or devices in the zone. The up or down symbols disappear when you reach the start or end of the list (or when there are no off-normal devices).
- (2) Device address: The panel (P), card (C), and device number (D) that constitute the complete device address for the device generating the event message.
- (3) Device message lines: If programmed, the device message for the device that generated the event message. This is usually a location description.

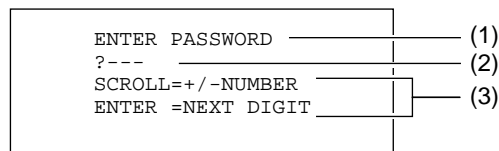
The Details screen provides details about the zone or device that generated the selected event message. If the selected event message is for a zone, the Details screen shows which devices in the zone are active.

## Example Details screen

```
DETAILS          v
P:01 C:01 D:001
East Wing Hallway
South Entrance
```

# Entering a password

When the Controls Enabled LED is off, you need to enter a password to enable the controls. When you press any of the control buttons, the system displays the Enter Password screen.



- (1) Title line: This is constant text.
- (2) Password: You use the Up and Down cursor buttons to scroll through the digits in each position of the password. Each number appears on this line, but is masked as soon as you press the Enter button.
- (3) Instruction lines: These lines prompt you to press the Up and Down cursor buttons to select a number, or the Enter button to select a number and move to the next position.

## To enter a password:

1. Press any of the control buttons.  
The system displays the Enter Password screen, with the cursor in the first position of the four-digit password field.
2. Press the Up or Down cursor button to scroll through the numbers until the correct number appears.
3. Press the Enter button to enter that number and move to the next position.  
When you press Enter, the system masks the number you just entered with an asterisk.
4. Repeat steps 2 and 3 until you've entered all four digits of the password.

If you make a mistake, pressing Enter before filling all four positions cancels the operation, and returns you to the System Normal screen. If you enter an invalid password, the system displays an error message and returns you to the Enter Password screen.

# Message priorities

Event messages are stored in a single list or queue. Within the queue they are sorted into priority according to the event type and the order of event occurrence. The priority of event types is shown in the following lists.

## US market

1. Alarm
2. Supervisory
3. Trouble
4. Other

## Canadian market

1. Fire alarm
2. Emergency/Life safety
3. Fire supervisory
4. Building/Property safety
5. Trouble
6. Other

**Note:** The Emergency and Building event types are only used when the K-R Series Remote Annunciator is connected to a VM-1 panel with C-CPU firmware version 1.40.00 and above, and the system is configured for the Canadian market.

