

MANUALE D'USO E MANUTENZIONE
USE AND MAINTENANCE MANUAL
BEDIENUNGS - UND WARTUNGSANLEITUNG
MANUEL D'EMPLOI ET D'ENTRETIEN
MANUAL DE USO Y MANTENIMIENTO
MANUAL DO UTILIZADOR E MANUTENÇÃO

ARM200

Automatismo per Cancelli a Battente - Uso Residenziale/Condominiale

Swing Gate Operator - Residential/Communities

Drehtorantrieb für Privat und Gewerbe

Automatisme pour Portails à Battant – Usage Résidentiel/Intensif

Accionador para Puertas Batientes – Uso Residencial/Comunidades

Automatismo para Portões de Batente - Residencial/Condominio/Intensivo



D_MNLOARM200 24-10-2016 - Rev.27

IT - Istruzioni originali



MADE IN
ITALY



DESCRIPTION

The **ARM200** automated system for swing gates is an electro-mechanical non-reversing actuator that transmits motion to the leaf via a worm screw system.

The actuator is available in more versions in 18V DC and 230V AC. The non-reversing system ensures the leaf is mechanically locked when the motor is not operating, but it is not intended as a high degree security deterrent against intrusion attempts and/or tampering. A convenient and safe release system with customised key makes it possible to manually move the leaf in the event of a malfunction or of a power failure.

ATTENTION:



The correct operation and the declared specifications only apply if TAU accessories and safety devices are used.



In the absence of a mechanical clutch, the use of a control unit with an adjustable electronic clutch, or the installation of a sensitive edge, is required in order to ensure crush-proof safety.



The **ARM200** automated system was designed and built for controlling vehicle access. It is not intended as a high degree security deterrent against intrusion attempts and/or tampering. Avoid any other use whatever.

ACTUATOR PARTS (fig.1)

Pos.	Description
1	Actuator
2	Release device
3	Rod
4	Wing connection bracket
5	Rear bracket
6	Terminal board cover

DIMENSIONS (fig.2)

INSTALLATION (fig.3)

Electrical set-up (standard system - ARM200)

Pos.	Description	Cables
1	Attuatore	4x1,5 mm ²
2	Control unit	3x1,5 mm ² (power supply)
3	TX photocells	4x0,5 mm ²
4	RX photocells	2x0,5 mm ²
5	Key-operated selector switch	3x0,5 mm ²
6	Flashing light and aerial	2x1 mm ² + 1RG58
7	Mechanical stops	-

Electrical set-up (standard system - ARM200BENC)

Pos.	Description	Cables
1	Attuatore	2x2,5 mm ² + 3x0,5 mm ²
2	Control unit	3x1,5 mm ² (power supply)
3	TX photocells	4x0,5 mm ²
4	RX photocells	2x0,5 mm ²
5	Key-operated selector switch	3x0,5 mm ²
6	Flashing light and aerial	2x1 mm ² + 1RG58
7	Mechanical stops	-

Notes:

- Use suitable tubes and/or hoses to lay electric cables
- Choose short routes for cables and keep power cables separate from control cables.

Preliminary checks

Prior to installing the automation, make all structural modifications in order to ensure safety distances and protect and segregate areas in which people may be exposed to the risk of crushing, shearing, dragging or similar dangers.

- Make sure the existing structure is sufficiently sturdy and stable;
- the mechanical parts must conform to the provisions of Standards EN 12604 and EN 12605;

- leaf length in compliance with the actuator specifications;
- regular and uniform movement of the leaves, without any friction and dragging during their entire travel;
- stiff hinges in good conditions;
- presence of both opening and closing mechanical limit stops;
- presence of an efficient earthing for electrical connection of the actuator.

Perform any necessary metalwork job before installing the automated system.

The condition of the gate structure directly affects the reliability and safety of the automated system.

Installation dimensions (fig.4)

Determine the fitting position of the actuator with reference to fig.4. Check with care if the distance between the open leaf and any obstacles (walls, fences etc.) is higher than the actuator dimensions.

ARM225I			
X°	A (mm)	B (mm)	C (mm)
90	110	120 ÷ 165	20 mm
90	115	120 ÷ 160	20 mm
90	120 ÷ 125	120 ÷ 155	20 mm
90	130	120 ÷ 150	20 mm
90	135	120 ÷ 145	20 mm
90	140	120 ÷ 140	20 mm
90	145	120 ÷ 135	20 mm
90	150 ÷ 155	120 ÷ 130	20 mm
90	160	120 ÷ 125	20 mm
90	165	120 ÷ 120	20 mm
100	130	120 ÷ 130	20 mm
100	135	120 ÷ 120	20 mm

ARM250I			
X°	A (mm)	B (mm)	C (mm)
90	120 ÷ 125	135 ÷ 275	20 mm
90	130	135 ÷ 270	20 mm
90	135	135 ÷ 265	20 mm
90	140	135 ÷ 260	20 mm
90	145 ÷ 150	135 ÷ 255	20 mm
90	155	135 ÷ 250	20 mm
90	160	135 ÷ 245	20 mm
90	165	135 ÷ 240	20 mm
90	170 ÷ 175	135 ÷ 235	20 mm
90	180	135 ÷ 230	20 mm
90	185	135 ÷ 225	20 mm
90	190 ÷ 195	135 ÷ 220	20 mm
90	200	135 ÷ 215	20 mm
100	145	135 ÷ 160	20 mm
100	150	135 ÷ 210	20 mm
100	155	135 ÷ 225	20 mm
100	160	135 ÷ 220	20 mm
100	165	135 ÷ 215	20 mm
100	170	135 ÷ 210	20 mm
100	170	135 ÷ 205	20 mm
100	180	135 ÷ 200	20 mm
100	185	135 ÷ 195	20 mm
100	190	135 ÷ 190	20 mm
100	195	135 ÷ 185	20 mm
100	200	135 ÷ 180	20 mm
110	170	135 ÷ 140	20 mm
110	175	135 ÷ 155	20 mm
110	180 ÷ 185	135 ÷ 175	20 mm
110	190	135 ÷ 165	20 mm
110	195	135 ÷ 160	20 mm
110	200	135 ÷ 155	20 mm

ARM270I

X°	A (mm)	B (mm)	C (mm)
90	150	170 ÷ 345	20 mm
90	155	170 ÷ 340	20 mm
90	160 ÷ 165	170 ÷ 335	20 mm
90	170	170 ÷ 330	20 mm
90	175 ÷ 180	170 ÷ 325	20 mm
90	185	170 ÷ 320	20 mm
90	190	170 ÷ 315	20 mm
90	195	170 ÷ 310	20 mm
90	200 ÷ 205	170 ÷ 305	20 mm
90	210	170 ÷ 300	20 mm
90	215	170 ÷ 295	20 mm
90	220 ÷ 225	170 ÷ 290	20 mm
100	175	170 ÷ 170	20 mm
100	180	170 ÷ 220	20 mm
100	185	170 ÷ 280	20 mm
100	190	170 ÷ 285	20 mm
100	195	170 ÷ 280	20 mm
100	200	170 ÷ 275	20 mm
100	205	170 ÷ 270	20 mm
100	210	170 ÷ 265	20 mm
100	215	170 ÷ 260	20 mm
100	220	170 ÷ 255	20 mm
100	225	170 ÷ 250	20 mm
110	210	170 ÷ 175	20 mm
110	215	170 ÷ 190	20 mm
110	220	170 ÷ 210	20 mm
110	225	170 ÷ 225	20 mm

When measurement "C" is greater/smaller than 20 mm, increase/decrease measurement "B" by the difference (e.g.: if C= 25mm, increase "B" by 5mm), making sure that it does not exceed the limits shown in the table.



Note: to work correctly, the angle formed by the actuator and the gate (Y° fig. 4) must be > 3° (ARM225 - ARM250) and > 4° (ARM270) both with the gate completely closed and completely open.



Note: for a quick opening and optimum closed-holding position (gates with an electrical lock), use the maximum dimension "B" shown in the tables.

If the pillar dimensions or the hinge position do not allow the installation of the actuator, a niche on the pillar, as shown in Fig. 5, should be created in order to maintain the A dimension as determined. The niche should be dimensioned in such a way to enable easy installation, actuator rotation and operation of the release device. The mounting brackets are designed to enable small adjustments in both directions (fig.5A), it is possible to use the two multipoint brackets overlapped (pict. 5B: in this case the only holes to be used are the 3 highlighted, according to the direction of the leaf movement). In any case, always refer to the measurements shown in the table. Please keep to the values given in the table and oil the gate's hinges.

- 1_ Fix the rear bracket in the position determined before. In the event of iron pillar carefully weld directly the bracket or use n°4 suitable screws (fig.6). In the event of brick pillar (fig.7), use n°4 suitable bolts (after you have assembled it, fig.7A).

During the fastening operations, check if the bracket is perfectly horizontal by means of a level.



WARNING - In case of large gate leaves and /or closed design leaves other than the installation of an electro lock it is suggested to strengthen the fastening of the back bracket (weld the steel parts instead of using screws to assemble the bracket, use steel anchors instead of the dowels, weld the bracket onto the pillar, etc.).

- 2_ Set the operator for manual operation (see paragraph **MANUAL RELEASE**).
- 3_ Completely extend the rod till it reaches the limit stop (1 fig.8).
- 4_ Lock the operator again (see paragraph **RESTORING NORMAL OPERATION**).
- 5_ Turn the rod clockwise half a revolution (2 fig.8).
- 6_ Assemble the front bracket as shown in fig.9. Fasten the screw

using the special nut and insert the self-lubricating bushing into the bracket as shown on Fig. 9.

- 7_ After removing the terminal board cover, anchor the actuator to the rear bracket using the screw and nut supplied (see 1 fig.10);

ATTENTION: The actuator can be moved by hand only if it is installed on the gate and in released position (see paragraph **MANUAL RELEASE).**



ATTENTION: carefully verify that, when gate is closed, the actuator's rear do not touch the bracket (see fig. 10). If so adjust the setting accordingly.

- 8_ Check measurement "L" according to the table (fig.4).
- 9_ rest the bracket that has just been fixed, onto the wing of the completely closed gate and mark the fixing points (make sure it is level, see fig. 11).

Before going on to the next phase please carry out the following test:

- 10_ Release the actuator (see paragraph **MANUAL RELEASE**) and manually check if the gate can completely open without hindrances and stop at the mechanical travel stoppers (floor-mounted mechanical stoppers) as well as if the leaf moves regularly without any friction.
- 11_ Carry out the necessary corrective measures and repeat from point 10. Manually open the gate to the maximum required angle;
- 12_ Tighten the arm until the front bracket finds itself over the position just marked on the gate.

If the small bracket does cover the position marked it means installation has been done correctly.

This method can be used to establish where the small bracket will have to be welded for each opening angle (X°) required provided it is possible (parameters A and B and the actuator's useful travel permitting).

- 13_ fasten the gate mounting bracket in the position indicated (fig.12), referring to the dimensions shown in fig. 13 and ensuring the planarity of the assembly.



Note: if the gate structure does not allow a fix bracket fastening it is necessary to create a sturdy supporting base in the gate structure.



Note: for complete safety, the mechanical stops with rubber cap (floor stops) must be fitted in opening and closing of the gate (7 fig. 3), in order that they intervene just before the mechanical piston stops.

WIRING THE ACTUATOR

A terminal board is fitted in the lower part of the actuator for the connection of the motor, of any limit switch and for the earthing of the actuator. (figg.14-15).

Connect the motor and the earthing with reference to fig.14-15 and to the table.

ARM200 - 230V AC		
POS.	COLOR	DESCRIPTION
1	Blue	Common cable
2	Brown	Phase 1
3	Black	Phase 2
T	Yellow / Green	Earthing

Connect up the condenser in parallel to the 2 phases of the motor (terminals 2 and 3). Warning! Do not short-circuit the two wires as this may cause discharges because of the current remaining in the wires. Use control units with torque limiting device only.

ARM200BENC - 18V DC		
POS.	COLOR	DESCRIPTION
1	Brown	Encoder positive
2	Blue	Encoder negative
3	White	Encoder signal
4	Black	Motor negative
5	Red	Motor positive

Only use control units fitted with an electric clutch. The distance between the control unit and the motor must not exceed 10 – 12 m. TAU srl recommends its composite cable, Code **M-03000010CO**;



Place the control unit (external versions) in the immediate vicinity of the motors.



Be careful not to run cables for auxiliary devices inside raceways housing other cables supplying power to large loads or lights with electronic starters.



In the event control pushbuttons or indicator lights are installed inside homes or offices several metres from the actual control unit, it is advisable to decouple the signal by means of a relay in order to avoid induced interference.

START-UP



ATTENTION: Cut power before any job on the system or on the actuator.

Carefully observe points 10, 11, 12, 13 and 14 of the SAFETY GENERAL RULES.

With reference to the indications in fig.3 and in the table (see paragraph **INSTALLATION**), set the ducts and carry out the electrical connections of the control board and of the chosen accessories. Choose short routes for cables and keep power cables separate from control cables.

- 1) Power the system and check the status of the LED's according to the control unit instructions.
- 2) Program the control board according to the needs by following the given instructions.

TESTING THE AUTOMATED SYSTEM

- Carefully check operating efficiency of the automated system and of all accessories connected to it, paying special attention to the safety devices.
- Hand the "User Guide" to the final user together with the Maintenance register.
- Explain correct operation and use of the automated system to the user.
- Indicate the potentially dangerous areas of the automated system to the user.

MANUAL RELEASE

If the automated system needs to be moved manually due to a power lack or to an actuator malfunction, proceed as follows:

- 1_ Cut power by means of the safety circuit breaker (even in the event of a power lack).
- 2_ Slide the protective cap, fig.16;
- 3_ Insert the key and turn it 90°, fig.17.
- 4_ As shown in fig.18, rotate the release lever upward in order to release the actuator.
- 5_ Open or close the leaf manually.



Note: To hold the actuator in manual operation the release device should be left in its current positions and the system should be without power.

RESTORING NORMAL OPERATION

To restore normal operating conditions, proceed as follows:

- 1_ Lock the release lever by rotating it downward.
- 2_ Turn 90° the release key and remove it.
- 3_ Close the protection cover.
- 4_ Power up the system and perform some movements in order to check the correct restoring of every function of the automated system.

USE

Actuators ARM225I - ARM225BI, ARM250I - ARM250BI e ARM270I - ARM270BI are designed to move gates with a maximum length of, respectively, 3.0, 4.0 and 5.0 metres.

It is expressly **forbidden to use the device for any other purposes or under any other circumstances other than those mentioned**. The electronic control unit (**which must be fitted with an electric clutch**) allows the following functions to be selected:

automatic : a command impulse opens and shuts the gate
semiautomatic : a command impulse opens or shuts the gate.
 In the event of a power failure, the gate may be moved manually by activating the "manual release" device. Mod. ARM200BENC can be powered by a buffer battery and is able to perform at least 15 complete cycles (open and close) on its own.

This is an electrically powered automatic device and should therefore be used with care. In particular:

- do not touch with wet hands and/or wet or bare feet;
- disconnect the power supply before opening the control box and/or the actuator;
- do not pull the plug out by its cable;
- do not touch the motor unless you are certain it is cool;
- only operate the gate when it is completely visible;
- do not approach the gate while it is moving;
- do not allow children or animals to play near the gate;
- do not allow children or disabled people to use the remote control or other operating devices;
- carry out routine maintenance;
- in the case of a fault, disconnect the power supply and only move the gate if it is possible and safe to do so. Do not touch the gate and call in an authorised technician.

MAINTENANCE

To ensure trouble-free operation and a constant safety level, an

overall check of the system should be carried out every 6 months. A form for recording operations has been included in the "User Guide" booklet.



ATTENTION: no-one, except for the maintenance man, who must be a specialised technician, must be able to use the automatic system during maintenance.

Switch off the mains power supply to eliminate the risk of electrocution. If the power supply must be left on for certain operations, each control device should be checked or disabled (remote controls, push button strips, etc.) except for the one used by the maintenance man.

The ARM200 / ARM200BENC actuators need very little maintenance. However, as the gate must be in good working order for them to work properly, the operations required to keep it in perfect condition are described below.

Routine maintenance

Each of the following operations must be carried out every 6 months for domestic use (approx. 3000 work cycles) and every 2 months for intensive use such as blocks of flats (always 3000 work cycles).



WARNING: In the event installation is to take place in areas exposed to a great deal of sea spray and/or sand (maritime regions, desert zones, etc.), maintenance will need to be performed at shorter intervals, every 2/3 months.

Gate:

- lubricate and grease the hinges of the gate.

Automation system:

- check the safety devices (photocells, pneumatic edge, etc.) work according to the manufacturer's instructions;
- grease (with a greaser) the worm screw from underneath the actuator (see fig.12); TAU srl recommends using the complex lithium soap grease produced by SYNECO.
- use a tester for lead-acid batteries to check whether the battery is charged; if it needs replacing use an original battery and recycle the flat one in compliance with current legislation (alternatively, TAU srl recommends using FIAMM batteries).



Note: with use, a thin line of oxide may form on the actuator stem. This is due to the materials addition when welding the tube/stem. However, in **NO WAY** does this affect the quality or normal operation of the gearmotor. We recommend the stem be cleaned regularly using special products for stainless steel.

Extraordinary maintenance or breakage

If major work on electromechanical parts must be carried out, the faulty component should be removed and repaired in the workshop by the maker's or other authorised technicians.

Keep all the documents concerning the system inside or near the control unit.

SPECIAL APPLICATIONS

There is no special application other than the described use.

NOISE LEVELS

Airborne noise generated by the gearmotor in normal operating conditions is constant and does not exceed 70 dB.

GUARANTEE: GENERAL CONDITIONS

TAU guarantees this product for a period of 24 months from the date of purchase (as proved by the sales document, receipt or invoice).

This guarantee covers the repair or replacement at TAU's expense (ex-works TAU: packing and transport at the customer's expense) of parts that TAU recognises as being faulty as regards workmanship or materials.

For visits to the customer's facilities, also during the guarantee period, a "Call-out fee" will be charged for travelling expenses and labour costs.

The guarantee does not cover the following cases:

- If the fault was caused by an installation that was not performed according to the instructions provided by the company inside the product pack.
- If original TAU spare parts were not used to install the product.
- If the damage was caused by an Act of God, tampering, overvoltage, incorrect power supply, improper repairs, incorrect installation, or other reasons that do not depend on TAU.
- If a specialised maintenance man does not carry out routine maintenance operations according to the instructions provided by the company inside the product pack.
- Wear of components.

The repair or replacement of pieces under guarantee does not extend the guarantee period.

In case of industrial, professional or similar use, this warranty is valid for 12 months.

<p>1</p>	<p>2</p>	<p>3</p>	<p>MANUAL RELEASE If the automated system needs to be moved manually due to a power lack or to an operator malfunction, proceed as follows:</p> <ol style="list-style-type: none">1_ Cut power by means of the safety circuit breaker (even in the event of a power lack).2_ Slide the protective cap, fig.16;3_ Insert the key and turn it 90°, fig.17.4_ As shown in fig.18, rotate the release lever upward in order to release the actuator.5_ Open or close the leaf manually. <p>Note: To hold the operator in manual operation the release device should be left in its current positions and the system should be without power.</p> <p>RESTORING NORMAL OPERATION To restore normal operating conditions, proceed as follows:</p> <ol style="list-style-type: none">1_ Lock the release lever by rotating it downward.2_ Turn 90° the release key and remove it.3_ Close the protection cover.4_ Power up the system and perform some movements in order to check the correct restoring of every function of the automated system.
----------	----------	----------	---

INSTRUCTIONS AND WARNINGS FOR AUTOMATIC SYSTEM USERS

CONGRATULATIONS on choosing a Tau product for your automation system!

Tau S.r.l. produces components for automatic gates, doors, barriers and shutters. These include gear motors, control units, radio control devices, flashing lights, photocells and accessories.

Tau products are exclusively made with top quality materials and processes and, as a company, we constantly research and develop innovative solutions in order to make our equipment increasingly easier to use. We also pay great attention to all details (technology, appearance and ergonomics). The extensive Tau range makes it possible for your fitter to choose the product which best meets your requirements.

Tau, however, does not produce your automated system as this is the outcome of a process of analysis, evaluation, choice of materials and installation performed by your fitter.

Each automated system is unique, therefore, and only your fitter has the experience and professionalism required to create a system that is tailor-made to your requirements, featuring long-term safety and reliability, and, above all, professionally installed and compliant with current regulations.

An automated system is handy to have as well as being a valid security system. Just a few, simple operations are required to ensure it lasts for years.

DESCRIPTION

The **ARM200** automated system for swing gates is an electro-mechanical non-reversing actuator that transmits motion to the leaf via a worm screw system.

The actuator is available in more versions in 12 Vdc and 230 Vac.

The non-reversing system ensures the leaf is mechanically locked when the motor is not operating. A convenient and safe release system with customised key makes it possible to manually move the leaf in the event of a malfunction or of a power failure.

Even if your automated system satisfies regulatory safety standards, this does not eliminate "residue risks", that is, the possibility of dangerous situations being generated, usually due to irresponsible and/or incorrect use. For this reason we would like to give you some suggestions on how to avoid these risks:

- **Before using the system for the first time:** ask your fitter to explain how residue risks can arise and read the instructions and warnings in the user handbook that your fitter will have given you. Keep this manual for future use and, if you should ever sell your automated system, hand it over to the new owner.
- **Your automated system carries out your commands to the letter:** irresponsible and/or incorrect use may cause it to become dangerous. Do not use the system if people, animals and/or objects enter its operating area.
- **IT IS NOT A TOY!** Make sure children do not play near the system and keep the remote control device out of their reach.
- **Faults:** If you notice any abnormal behaviour, disconnect the system from the power supply immediately and perform the manual release operation (see figure). Do not attempt to repair the door but call in your fitter: the system will operate manually as it did before installation.
- **Maintenance:** to ensure long life and totally safe operation, the system required routine maintenance, just like any other piece of machinery. Establish maintenance times together with your fitter. Tau recommends a frequency of 6 months for normal domestic installations but this may vary depending on the intensity of use (always every 3000 work cycles).

Note: All controls, maintenance work and/or repairs may only be carried out by qualified personnel.

- Do not modify the plant or the relative programming and adjustment parameters: your fitter will see to that.

Note: Final testing, routine maintenance and any repairs must be documented by the fitter (in the relative spaces) and such documents kept by the owner of the system (IF THE DOCUMENTS ARE NOT PRODUCED, THE WARRANTY WILL EXPIRE).

- **Disposal:** At the end of system life, make sure that it is demolished by qualified personnel and that the materials are recycled or disposed of according to local regulations.

The manual manoeuvre must ONLY be done with the door stopped and AFTER disconnecting power from the electrical control unit.

Note: if your remote control unit (if supplied) starts working badly after a time, or does not work at all, the batteries may be flat (they can last from several months to 2/3 years depending on what type is used). This can be seen from the fact that the transmission confirmation LED gets dimmer or only turns on for brief moments. Before contacting your fitter, try exchanging the battery with one from a good transmitter: if this is the reason for the fault, simply replace the battery with another one of the same type.

If you wish to add a new automated system to your house, contact your fitter and we at Tau to have the advice of a specialist, the most developed products on the market, best operation and maximum automation compatibility.

Thank you for reading these suggestions and we trust you are fully satisfied with your new system: please contact your fitter for any further requirements.

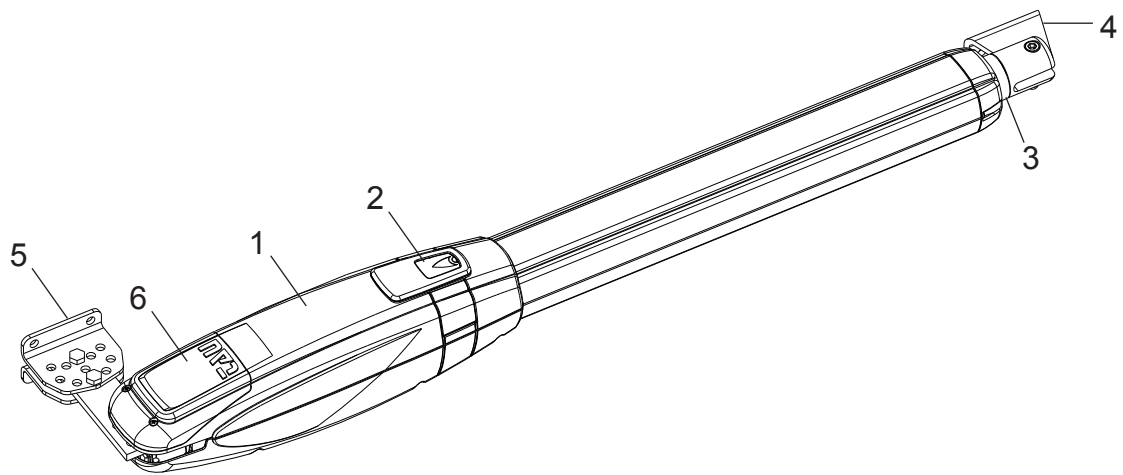
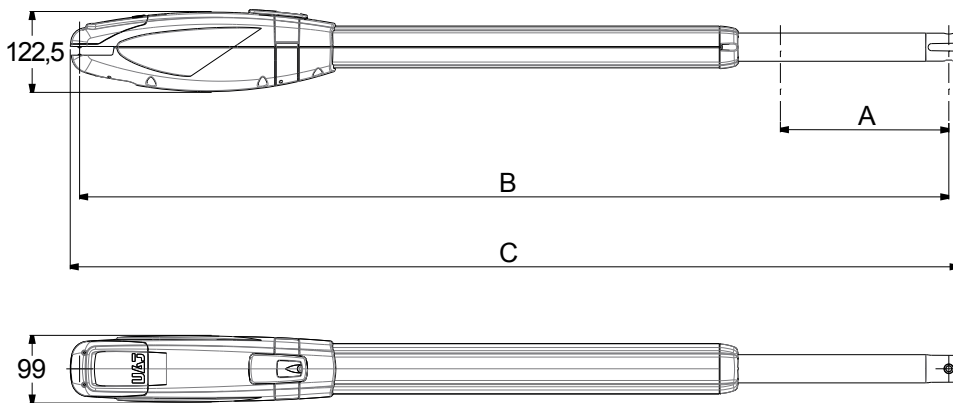

fig. 1



ARM	A	B max	C max
225l - 225Bl	290mm	1070mm	1098mm
250l - 250Bl	425mm	1350mm	1378mm
270l - 270Bl	530mm	1560mm	1588mm

fig. 2

	ARM200	ARM200BENC
a	4x1,5 mm ²	2x2,5 mm ² + 3x0,5 mm ²
b	3x1,5 mm ²	3x1,5 mm ²
c	2x0,5 mm ²	2x0,5 mm ²
d	4x0,5 mm ²	4x0,5 mm ²
e	3x0,5 mm ²	3x0,5 mm ²
f	2x1 mm ² + 1RG58	2x1 mm ² + 1RG58

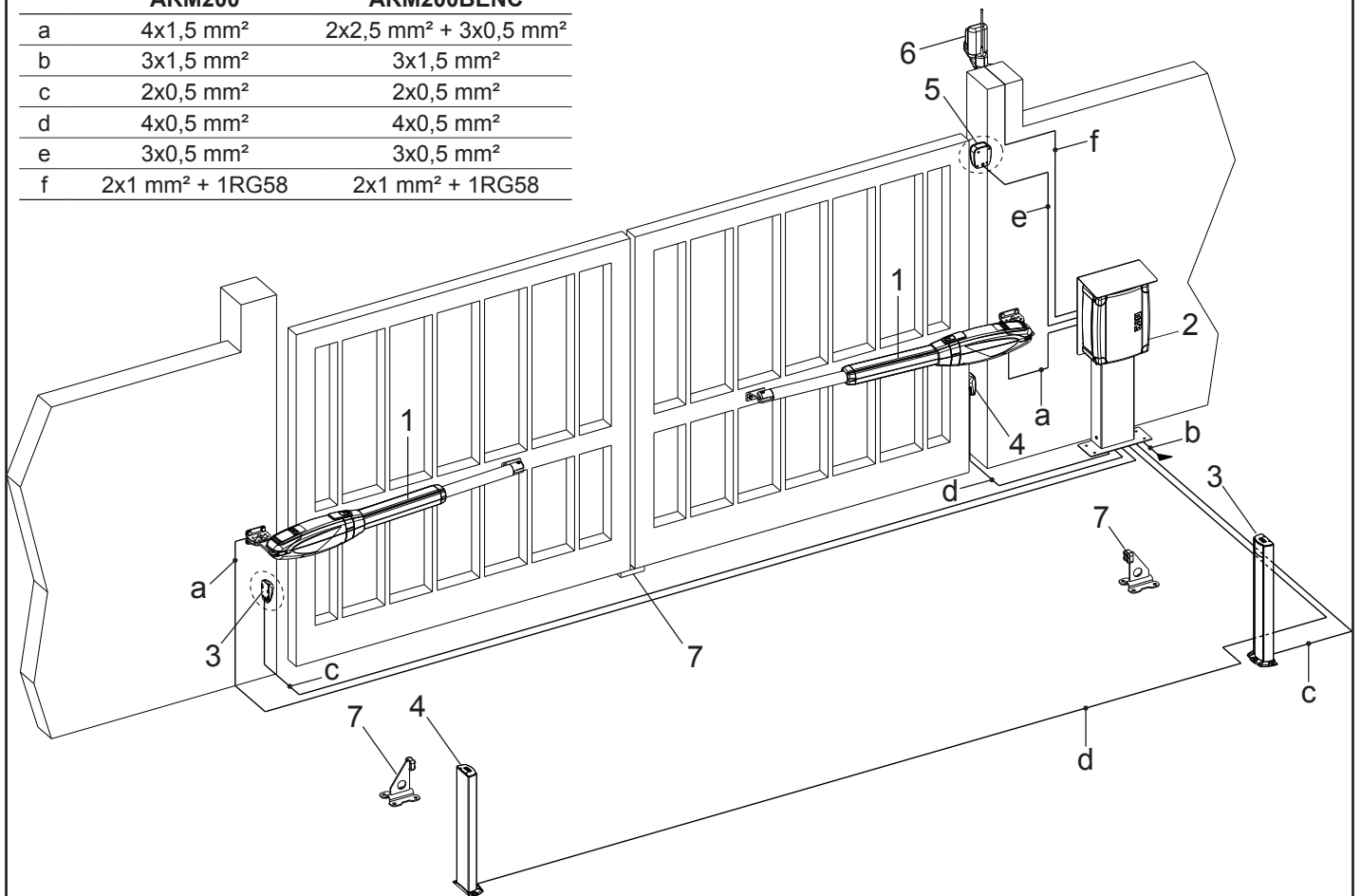

fig. 3

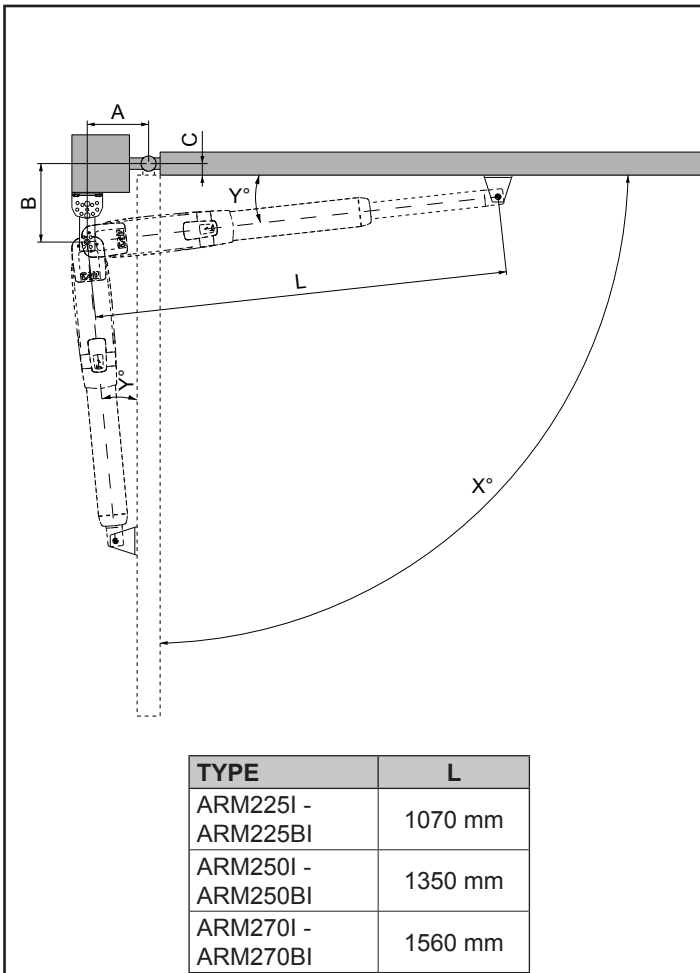

fig. 4

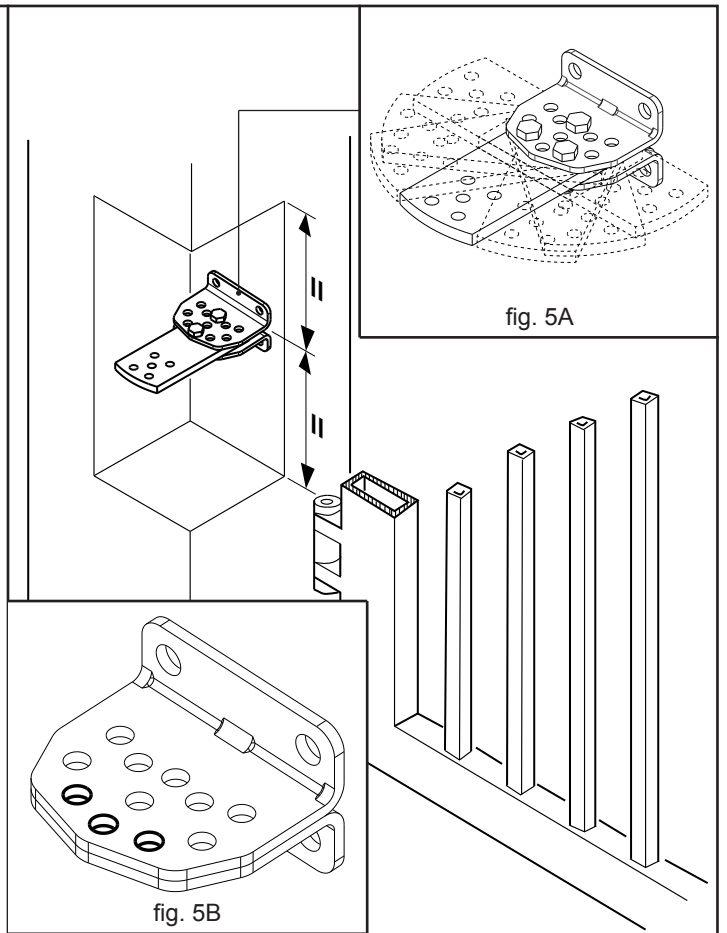

fig. 5A

fig. 5B

fig. 5

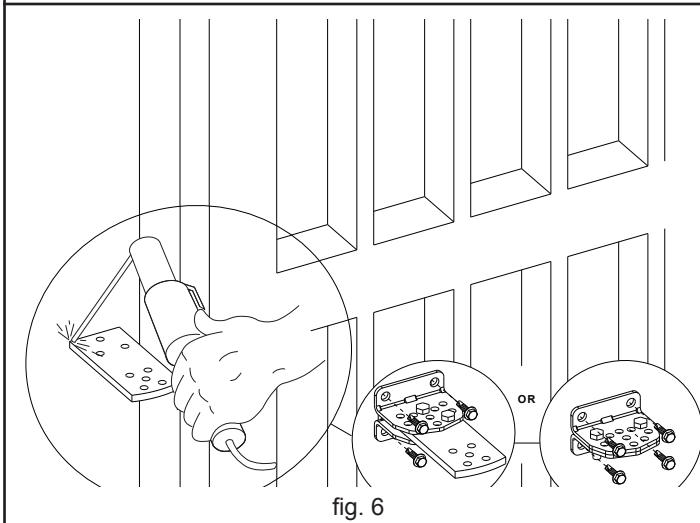

fig. 6

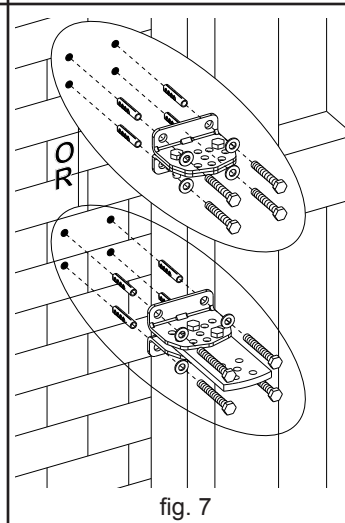

fig. 7

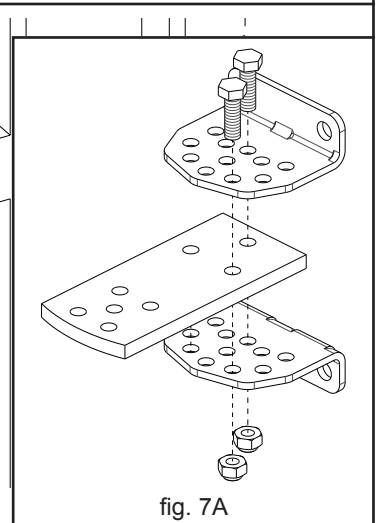

fig. 7A

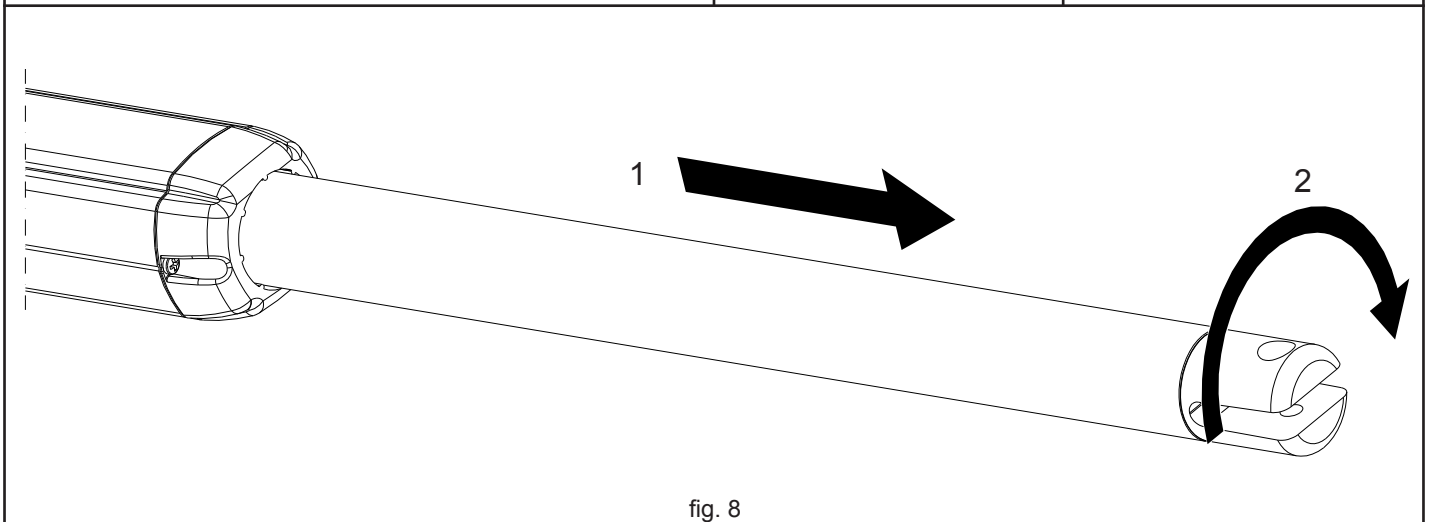

fig. 8

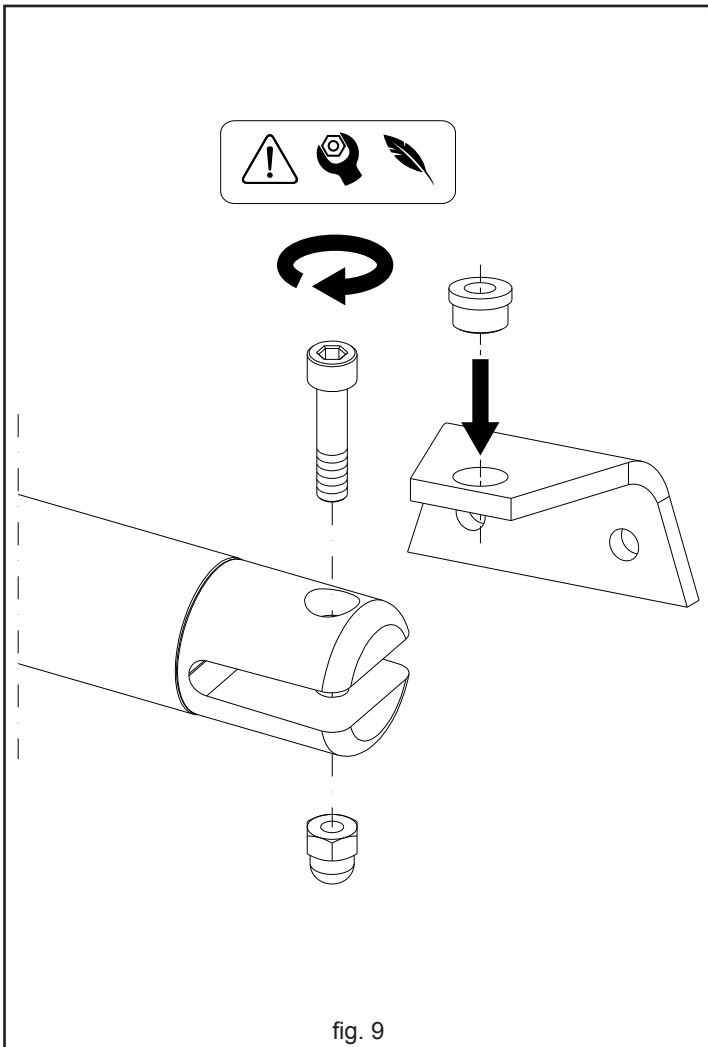

fig. 9

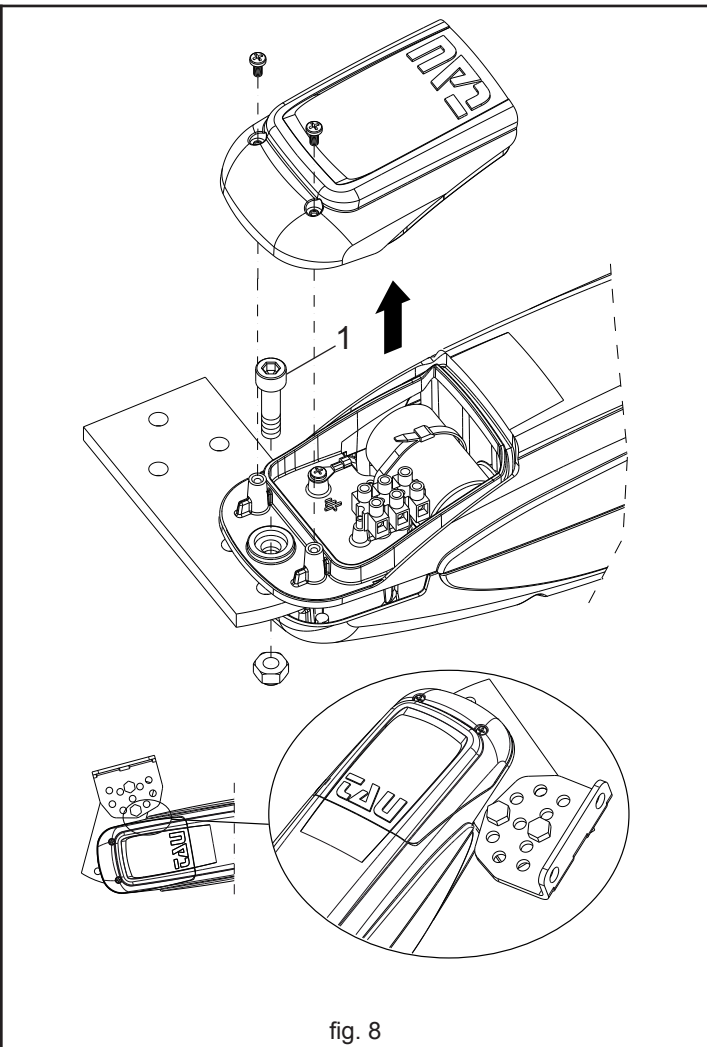

fig. 8

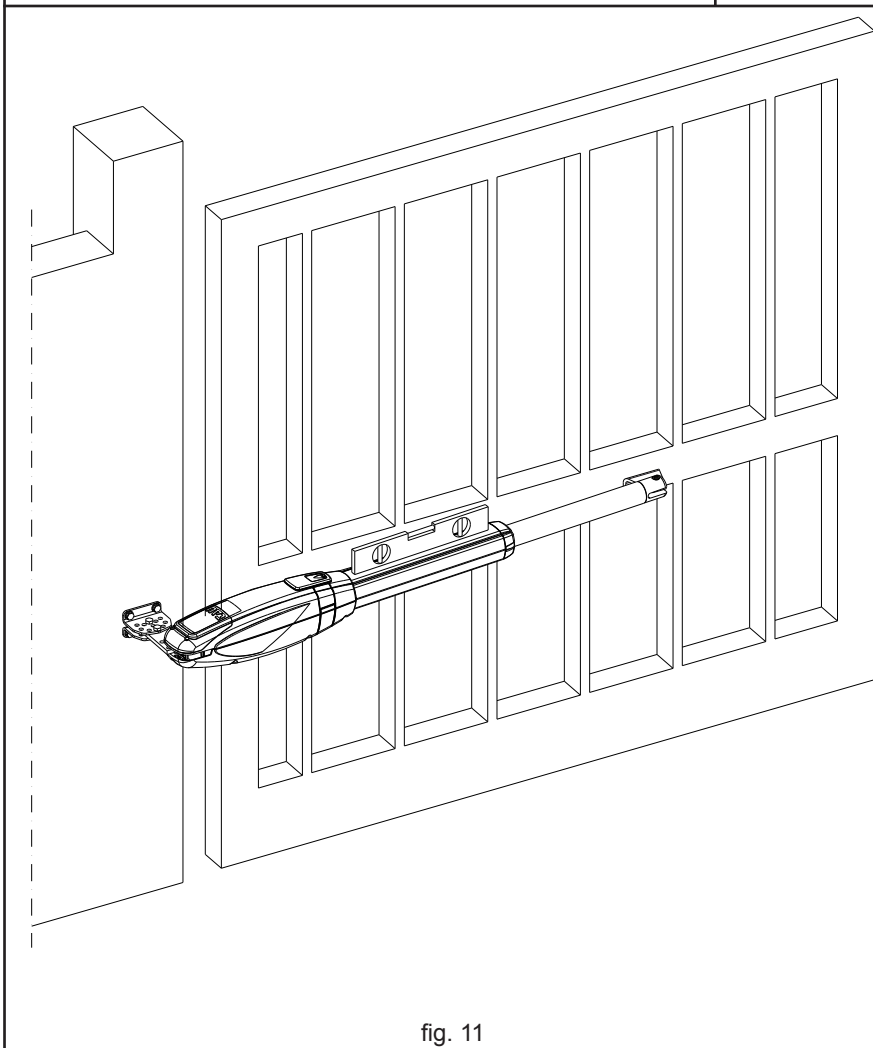

fig. 11

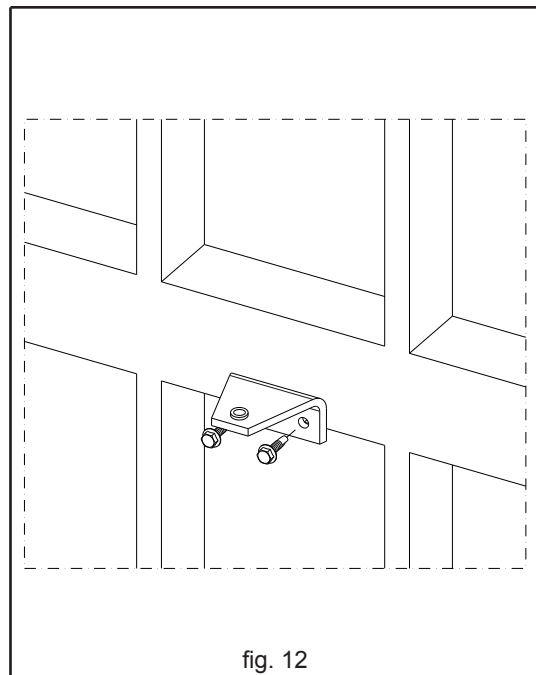

fig. 12

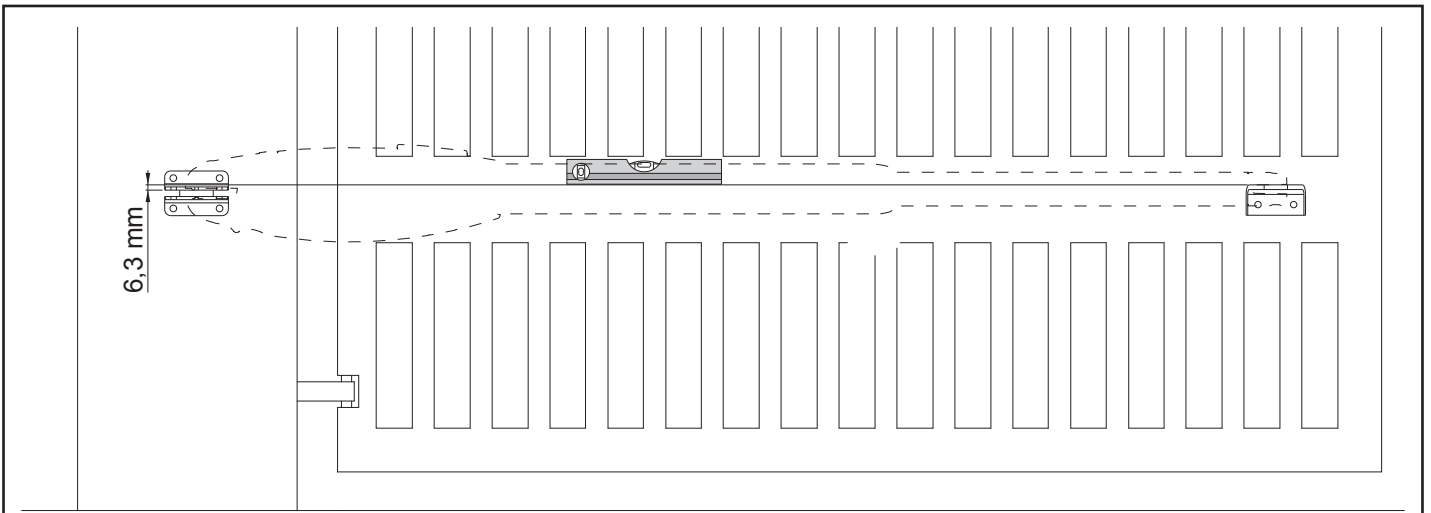

fig. 13

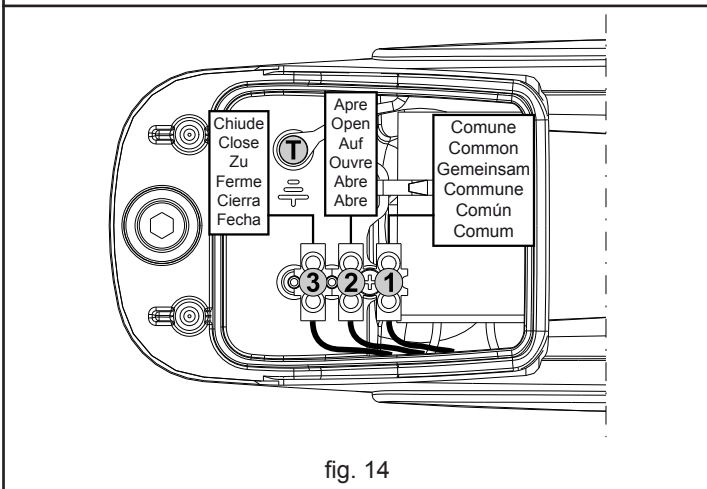

fig. 14

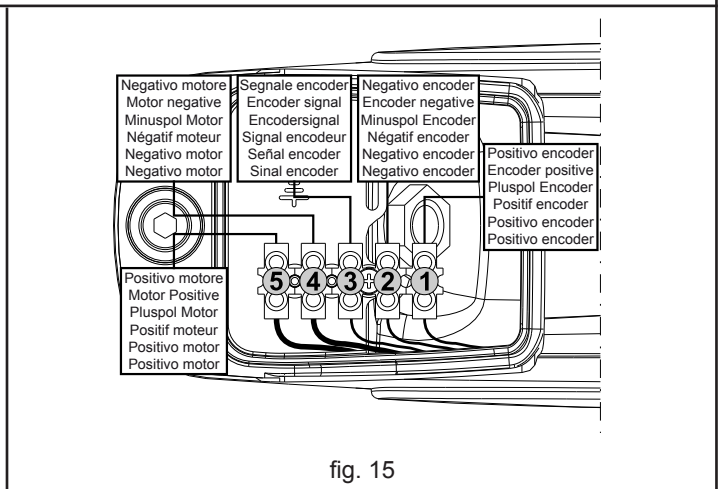

fig. 15

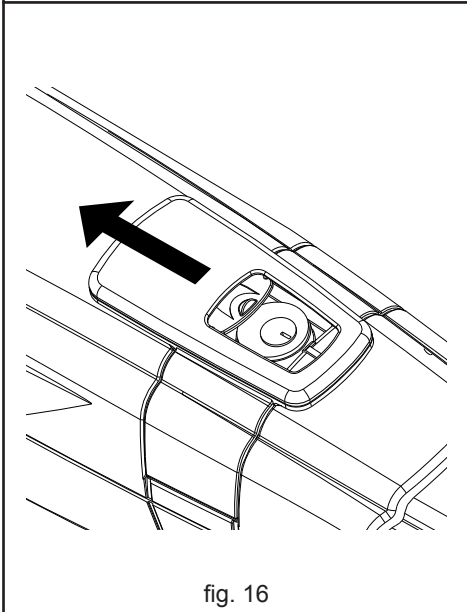

fig. 16

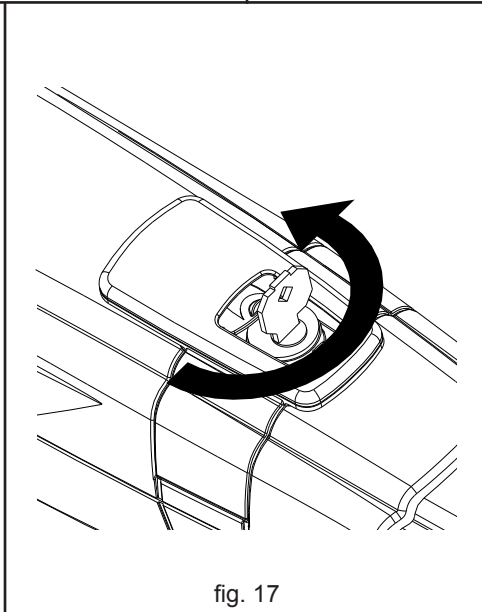

fig. 17

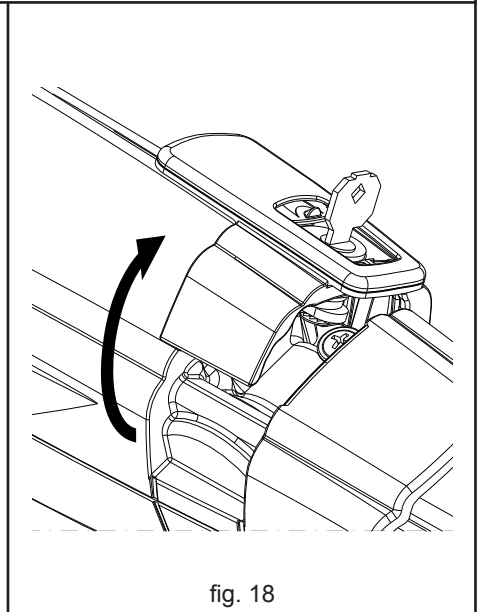

fig. 18

Example mounting: Opening outwards
Esempio di montaggio per apertura anta verso l'esterno.

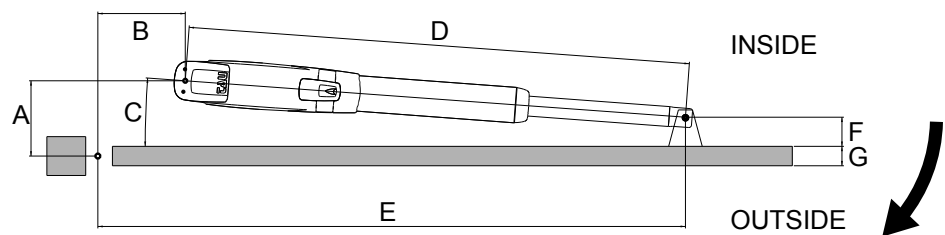

fig. 19

TYPE	A	B	C	D	E	F	G
ARM225I - ARM225BI	125 mm	145 mm	3,3°	781 mm	925 mm	60 mm	40 mm
ARM250I - ARM250BI	130 mm	145 mm	3,1°	931 mm	1075 mm	60 mm	40 mm
ARM270I - ARM270BI	155 mm	180 mm	4,2°	1032 mm	1210 mm	60 mm	40 mm

SELF INSTALL - NEED TECHNICAL ASSISTANCE?

OPTION 1: DIRECT WITH THE SERVICE DESK – QUICKEST AND MOST EFFECTIVE METHOD

Submit your enquiry direct with the service desk at – service@automaticsolutions.com.au

The service desk has the most experienced staff in Australia to help with your problem but they need your help.

- Describe your problem in detail and as clearly as possible. Don't forget to include a telephone number.
- Be certain to detail which model or models of you are working with.
- Send photos of the installation – they love photos. The people at the service desk are good but they are even better when they can see the installation. Send photos of the overall scene so they can see the entire installation. Also send photos of the wiring to the control board and any other part of the installation you think is relevant.
- Send video if appropriate. Smartphone's these days take remarkably good video in small file sizes which can be emailed in a moment. If your problem needs a video to show the issue please feel free to send it.

**NOTE: THIS IS BY FAR THE FASTEST AND MOST SUCCESSFUL WAY TO SOLVE YOUR PROBLEM
PHOTOS AND VIDEOS ARE THE NEXT BEST THING TO BEING THERE**

OPTION 2: LODGE YOUR ENQUIRY LOCALLY - SLOWER BUT CAN STILL BE EFFECTIVE

Make contact with the store of purchase. Branch staffs are typically not technicians and dependent on their length of service will have varying degrees of technical knowledge. If they cannot help however they will certainly either source help locally from their technicians or make contact with the service technicians on your behalf.

OPTION 3: SERVICE CALL WITH AUTOMATIC SOLUTIONS TECHNICIAN – SLOWEST METHOD

If you fall within the local branch service area it may be possible to book a local technician to look at your installation. Wait times will vary dependent on local workloads. The cost is a service fee which includes the first half hour and the hourly rate thereafter. If any Automatic Solutions provided parts are found to be defective and within warranty these will be provided free of charge.

(NOTE: If you suspect that any parts are defective and within warranty you may wish to consider option 4)

A note on this option: If you decide on this option you will be asked to sign an "authorisation to proceed" which will provide legal authority and payment security. This form has three options available of which only the first two are available to you. The third option is for warranty repairs only for full install customers. Self install customers requiring warranty only service need to refer to option four below.

IMPORTANT: IN SHORT THIS OPTION WILL INCUR CHARGES

OPTION 4: RETURN THE PRODUCT IF BELIEVED TO BE FAULTY

As a self install customer who has purchased product if you believe the product to be faulty rather than an installation or site problem you have the option of returning the product for evaluation and to exercise your right to a replacement, repair or refund as applicable. All returned product is forwarded immediately to the service technicians for evaluation and response. There are two main methods available to return product –

- Direct to the service centre – this is the quickest method as it cuts out the branch delay
- Via the branch of purchase – slower because of the delay at the branch

When choosing this option you need to complete a product return form. This form gives you all the information on procedure involved and where to send to. These are available at the branch of purchase, can be emailed to you (contact your branch), or available here - <http://automaticsolutions.com.au/page/warranty.php>