



Isolator Module

GSA-IM



Patented

Overview

The GSA-IM Isolator Module is part of Vigilant's Signature Series system. This intelligent device enables part of the Signature data loop to continue operating should a short circuit occur. The module can be wired into a Class A data loop at any point.

If a fault occurs, the isolator cuts power to all devices beyond the isolator on the loop as follows:

- a short on the line causes all isolators to open within 23 msec.
- at 10 msec intervals, beginning on one side of the Class A circuit nearest the loop controller, the isolators close to provide the next isolator down the line with power.
- when the isolator next to the short closes, it reopens within 10 msec.

Once activated, the line fault isolator continuously checks the faulted side of the loop to determine if the short still exists. When the fault is removed, the module automatically restores the entire data loop to the normal condition.

The microprocessor in every Signature module provides at least three important benefits — Self-diagnostics and History Log, Automatic Device Mapping, and Fast, Stable Communication.

Self-diagnostics and History Log - Each Signature Series module constantly runs self-checks to provide important maintenance information. This information is automatically updated and permanently stored in the module's non-volatile memory and is accessible for review any time using the SIGA-PRO Signature Program / Service Tool.

Automatic Device Mapping - The Signature loop controller learns and keeps a map where each device's serial number address is installed relative to other devices on the data circuit.

Fast Stable Communication - Built-in intelligence means less information needs to be sent between the module and the loop controller. Other than regular supervisory polling response, the module only needs to communicate with the loop controller when it has something new to report.

Standard Features

- **Automatic device mapping**
Each module transmits wiring information to the loop controller regarding its location with respect to other devices on the circuit.
- **Electronic addressing**
Addresses are downloaded and permanently stored from a PC, or the SIGA-PRO Signature Program / Service Tool. There are no switches or dials to set.
- **Ground fault detection by address**
Detects ground faults right down to the device level.
- **Self-restoring**
- **2-gang mounting**
- **Designed to ISO 9001 standards**

Testing & Maintenance

The module's automatic self-diagnosis identifies when it is defective and causes a trouble message. The user-friendly maintenance program shows the current state of each module and other pertinent messages. Single modules may be turned off (deactivated) temporarily, from the control panel. Availability of maintenance features is dependent on the fire alarm system used. Scheduled maintenance (Regular or Selected) for proper system operation should be planned to meet the requirements of the Authority Having Jurisdiction (AHJ). Refer to current NFPA 72 and ULC CAN/ ULC 536 standards.

Warnings & Cautions

This module will not operate without electrical power. As fires frequently cause power interruption, we suggest you discuss further safeguard with your fire protection specialist.

Typical Wiring and Installation

The GSA-IM module mounts to North American 2-1/2 inch (64 mm) deep 2-gang boxes and 1-1/2 inch (38 mm) deep 4 inch square boxes with 2 gang covers and GSA-MP mounting plates. The module will accept #18 AWG (0.75mm²), #16 (1.0mm²), #14 AWG (1.50mm²), and #12 AWG (2.50mm²) wire sizes. *Note: Sizes #16 AWG (1.0mm²) and #18 AWG (0.75mm²) are preferred for ease of installation. See Signature Loop Controller catalog sheet for detailed wiring requirement specifications.*

Edwards recommends that this module be installed according to latest recognized edition of national and local fire alarm codes.

Application & Compatibility

This module should only be used on Class A circuits. The operation of the GSA-IM is determined by its hardware type code and is assigned at the factory. No user configuration is required. The Signature Series modules are compatible only with Vigilant's Signature Loop Controller.

Typical Wiring

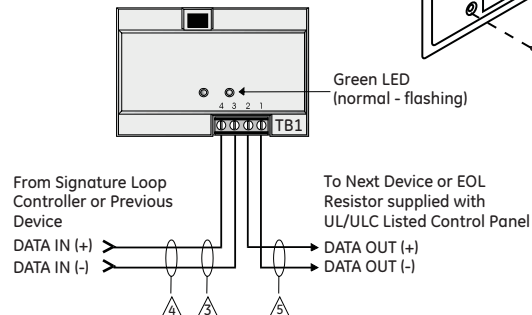
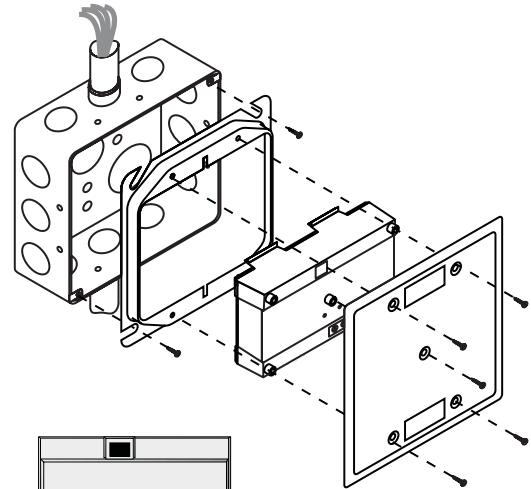
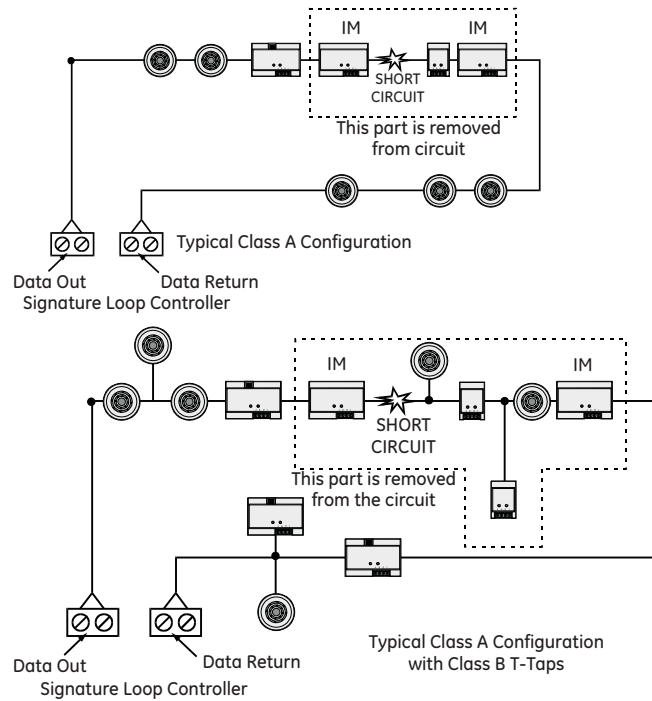

- ⚠ For maximum wire resistance, refer to the appropriate manufacturer's documentation.
- ⚠ Max. #12 AWG (2.5mm²) wire.
- ⚠ Refer to Signature Loop Controller Installation Sheet for wiring specifications.
- ⚠ This module should be used only with Class A wiring.
- ⚠ Maximum circuit resistance between isolators is 6 ohms.
- ⚠ All wiring is power-limited and supervised.

Specifications

Description	Isolator Module - factory set hardware type code
Address Requirements	Uses One Detector Address
Circuit Resistance	Six ohms maximum between isolators
Operating Current	Standby = 45µA; Activated = 45µA
Operating Voltage	15.2 to 19.95 Vdc (19 Vdc nominal)
Construction & Finish	High Impact Engineering Polymer 2-gang front plate - White Finish
Storage Environment	Temperature: -4°F to 140°F (-20°C to 60°C)
Operating Environment	Temperature: 32°F to 120°F (0°C to 49°C); Humidity: 0 to 93% RH
LED Operation	On-board Green LED - Flashes when polled (normal)
Compatibility	Use with: Signature Loop Controller
Agency Listings	UL, ULC, CSFM, MEA

Ordering Information

Catalog Number	Description	Ship Wt. lb (kg)
GSA-IM	Fault Isolator Module - UL/ULC Listed	.5 (.23)

Accessories

27193-21	Surface Mount Box - 2-gang RED	1 (.4)
27193-26	Surface Mount Box - 2-gang WHITE	
MFC-A	Multifunction Fire Cabinet - Red, supports Signature Module Mounting Plates	7.0 (3.1)
GSA-MP1	Signature Module Mounting Plate, 1 footprint	1.5 (0.70)
GSA-MP2	Signature Module Mounting Plate, 1/2 footprint	0.5 (0.23)
GSA-MP2L	Signature Module Mounting Plate, 1/2 extended footprint	1.02 (0.46)



Detection & alarm since 1872

U.S.

T 888 244 9979

F 866-503-3996

Canada

Chubb Edwards

T 519 376 2430

F 519 376 7258

Southeast Asia

T : +65 6391 9300

F : +65 6391 9306

India

T : +91 80 4344 2000

F : +91 80 4344 2050

Europe

T +32 2 725 11 20

F +32 2 721 86 13

Latin America

T 305 593 4301

F 305 593 4300

utcfireandsecurity.com

© 2010 UTC Fire & Security.

All rights reserved.
