

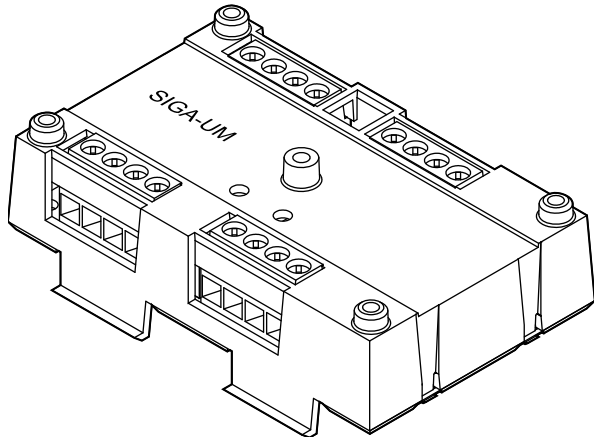

SIGA-UM Universal Class A/B Module Installation Sheet



Description

The SIGA-UM Universal Class A/B Module is an addressable module that you can configure to provide one of the following:

- Two Class B dry contact initiating device circuits
- One Class A dry contact initiating device circuit
- One Class A or Class B notification appliance circuit
- One Class A or Class B verified two-wire (conventional) smoke detector circuit without dry contact initiating devices on the same circuit
- One Class A or Class B unverified two-wire (conventional) smoke detector circuit with or without dry contact initiating devices on the same circuit
- One Form C dry contact relay output

The SIGA-UM requires two device addresses on the signaling line circuit (SLC). Addresses are assigned electronically. There are no addressing switches.

Diagnostic LEDs provide visible indication of the status of the module:

- Normal: Green LED flashes
- Alarm/active: Red LED flashes

Personality codes

Use the personality codes described below to configure the SIGA-UM module. See Table 1 on page 2 for listing information. See Table 2 on page 8 for personality code electrical characteristics.

Personality code 1: Alarm - NO latching (Class B). Factory default. Configures input 1 or 2 for Class B, normally open dry contact initiating devices (e.g., pull stations, heat detectors, etc.). When the NO input contact of an initiating device is closed, an alarm signal is sent to the loop controller and the alarm condition is latched at the module.

Personality code 2: Alarm - NO delayed latching (Class B). Same as code 1 except that contact closure must be maintained for approximately 16 seconds before an alarm signal is sent. This code is only for use with nonretarded waterflow alarm switches.

Personality code 3: Active - NO nonlatching (Class B). Contact closure causes an active instead of an alarm status and does not latch at the module. Code 3 is typically used for monitoring fans, dampers, and doors.

Personality code 4: Active - NO latching (Class B). Contact closure causes an active instead of an alarm status, which is latched at the module. Code 4 is typically used for monitoring supervisory and tamper switches.

Personality code 8: Signal - dry contact output. Configures the module as a Form C dry relay contact to control external appliances (door closers, fans, dampers) or equipment shutdown. Note: Jumper JP1 must be moved to pins 2 and 3 for dry contact operation.

Personality code 9: Alarm - NO latching (Class A). Configures the module for connection of Class A, normally open dry contact initiating devices (e.g., pull stations, heat detectors, etc.). When the NO input contact of an initiating device is closed, an alarm signal is sent to the loop controller and the alarm condition is latched at the module.

Personality Code 10: Alarm - NO delayed latching (Class A). Same as code 9 except that contact closure must be maintained for approximately 16 seconds before an alarm signal is sent. Code 10 is typically used with waterflow alarm switches.

Personality code 11: Active - NO nonlatching (Class A). Same as code 9 except that contact closure causes an active instead of an alarm status, and does not latch at the module. Personality code 11 is typically used for monitoring fans, dampers, and doors.

Personality code 12: Active - NO latching (Class A). Same as code 9 except that contact closure causes an active instead of an alarm status, which is latched at the module. Code 12 is typically used for monitoring supervisory and tamper switches.

Personality code 13: Alarm - two-wire smoke unverified (Class B). Configures the module for monitoring two-wire conventional smoke detectors (that do not require alarm verification) and normally open contact initiating devices (e.g., pull stations, heat detectors, etc.) on the same circuit.

Personality code 14: Alarm - two-wire smoke verified (Class B). Configures the module for monitoring two-wire conventional smoke detectors (that require alarm verification). Normally open contact initiating devices may not be mixed with two-wire conventional smoke detectors.

Personality code 15: Signal - supervised output (Class A). Configures the module for connection of a Class A output notification appliance circuit (NAC). Code 15 is typically used to control bells, speakers, etc.

Personality code 16: Signal - supervised output (Class B). Configures the module for connection of a Class B output notification appliance circuit (NAC). Code 16 is typically used to control bells, speakers, etc.

Personality code 18: Alarm - soft short latching, European Style C (Class B). A contact closure causes an alarm status and a short condition causes a trouble status. Personality code 18 is typically used when a short condition must be distinguished from an alarm condition.

Personality code 20: Alarm - two-wire smoke unverified (Class A). Same as personality code 13, except that wiring is Class A.

Personality code 21: Alarm - two-wire smoke verified (Class A). Same as personality code 14, except that wiring is Class A.

For personality codes 13, 14, 20 and 21

First SIGA-UM on a loop to go into alarm will maintain the 2 wire detector circuit voltage and current so that the 2 wire detector can maintain its LED. Second SIGA-UM on the same loop to get an alarm from a 2 wire detector will indicate the alarm at the control panel but will reduce voltage and current on its 2 wire circuit causing the detector LED to turn on and off.

Installation

Install this device in accordance with applicable national and local codes, ordinances, and regulations.

WARNINGS

- Connecting a device that exceeds this module's pilot duty contact ratings may cause activation failure. This module does not support capacitive loads. See "Specifications" on page 7.
- The personality code for this device is factory set to 0. This module will not operate until it is assigned a personality code of 1, 2, 3, 4, 8, 9, 10, 11, 12, 13, 14, 15, 16, 18, 20, or 21.
- Electrocution hazard. Dangerous voltages may be present at the module terminals even when power is shut off.

Table 1: Personality code listing information

| Code | Description | UL 864 | CAN/ULC-S527 | EN 54-18 |
|------|---|--------|--------------|----------|
| 1 | Alarm - NO latching (Class B) (default) | ✓ | ✓ | |
| 2 | Alarm - NO delayed latching (Class B) | | | |
| 3 | Active - NO nonlatching (Class B) | ✓ | ✓ | ✓ |
| 4 | Active - NO latching (Class B) | ✓ | ✓ | ✓ |
| 8 | Signal - dry contact output | ✓ | ✓ | ✓ |
| 9 | Alarm - NO latching (Class A) | ✓ | ✓ | |
| 10 | Alarm - NO delayed latching (Class A) | | | |
| 11 | Active - NO nonlatching (Class A) | ✓ | ✓ | ✓ |
| 12 | Active - NO latching (Class A) | ✓ | ✓ | ✓ |
| 13 | Alarm - two-wire smoke unverified (Class B) | ✓ | ✓ | |
| 14 | Alarm - two-wire smoke verified (Class B) | ✓ | ✓ | |
| 15 | Signal - supervised output (Class A) | ✓ | ✓ | ✓ |
| 16 | Signal - supervised output (Class B) | ✓ | ✓ | ✓ |
| 18 | Alarm - soft short latching, European Style C (Class B) | | | ✓ |
| 20 | Alarm - two-wire smoke unverified (Class A) | ✓ | ✓ | |
| 21 | Alarm - two-wire smoke verified (Class A) | ✓ | ✓ | |

Notes

- The module is shipped from the factory as an assembled unit; it contains no user-serviceable parts and should not be disassembled.
- This module does not operate without electrical power. As fires frequently cause power interruption, discuss further safeguards with the local fire protection specialist.
- This module does not support conventional four-wire smoke detectors.

To install the module:

1. Write the address assigned to the module on the label provided and apply the label to the module. Remove the serial number label from the module and attach it to the project documentation.
2. Wire in accordance with “Wiring” below.
3. Using the self-tapping screw provided, attach the wall plate to the module. See Figure 1.
4. Using the four machine screws provided, attach the wall plate and module to the electrical box.

Figure 1: Installing the SIGA-UM module

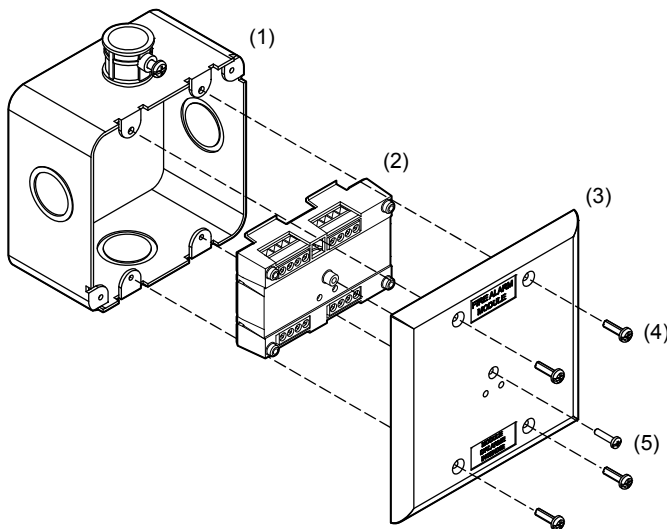

- | | |
|-------------------------------|------------------------------------|
| (1) Compatible electrical box | (4) #6-32 × 5/8 machine screw (4X) |
| (2) SIGA-UM module | (5) #4 × 1/2 self-tapping screw |
| (3) Wall plate | |

Protection from transient spikes

For installations in which the output circuit connects to electromechanical bells or horns, install a bipolar transient protector (P/N 235196P) to protect the module from transient spikes caused by switching inductive loads. Locate bells and horns at least 6 ft. (1.8 m) from the module.

To install a transient protector:

1. Install the transient protector across the output circuit inside the electrical box with the module. See Figure 2.

Figure 2: Bell circuit showing bipolar transient protector placement

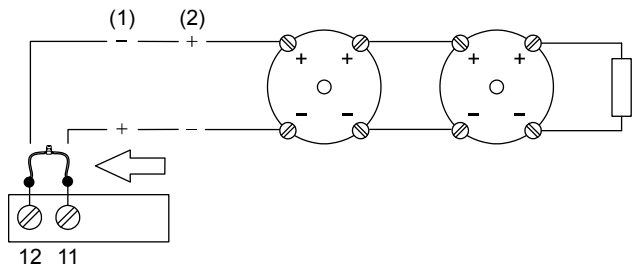

- (1) Normal state (2) Active state

Wiring

Wire this device in accordance with applicable national and local codes, ordinances, and regulations.

General wiring notes

- Refer to the Signature loop controller installation sheet for SLC wiring specifications.
- Each terminal on the module is limited to a single conductor.
- Only personality codes 13, 14, 20, and 21 support two-wire smoke detectors.
- Test resistors are supplied with the SIGA-UM to prevent trouble signals on unused circuits during installation. When connecting field wires, remove the test resistors and install a UL/ULC Listed 47 kΩ EOLR at the end of the circuit.

Riser wiring notes

- For maximum line impedance, refer to the installation manual for the fire alarm panel. Maximum circuit capacitance is 0.1 μF.
- If the riser is used for more than one notification zone, install in accordance with the survivability from attack by fire requirements in NFPA 72 *National Fire Alarm and Signaling Code*.

Two-wire smoke detector notes

- A maximum of 15 SIGA-UM modules per circuit can be configured to support two-wire smoke detectors (personality codes 13, 14, 20, and 21). However, if a Signature Series IM module or Signature Series detector with an isolator base is installed on the SLC, only 7 SIGA-UM modules may be configured to support two-wire smoke detectors.
- Use compatible smoke detectors. See the control panel compatibility list for type and quantity.

- Polarity at terminals is shown in the supervisory condition. Connect as shown in the diagram. (Polarity reverses on alarm.)
- IDC wiring is Style B (Class B) or Style D (Class A).

To wire the module:

1. Verify that all field wiring is free of opens, shorts, and ground faults.
2. Strip 1/4 in. (about 6 mm) from the ends of all wires that connect to the terminal block of the module.

When stripping wire ends, exposing more wire may cause a ground fault; exposing less wire may result in a faulty connection.

3. Make all wiring connections using the appropriate figure below for the desired function (personality code). See Figure 3 to Figure 7.

Figure 3: Class B initiating device circuit (personality codes 1, 2, 3, 4, 18)

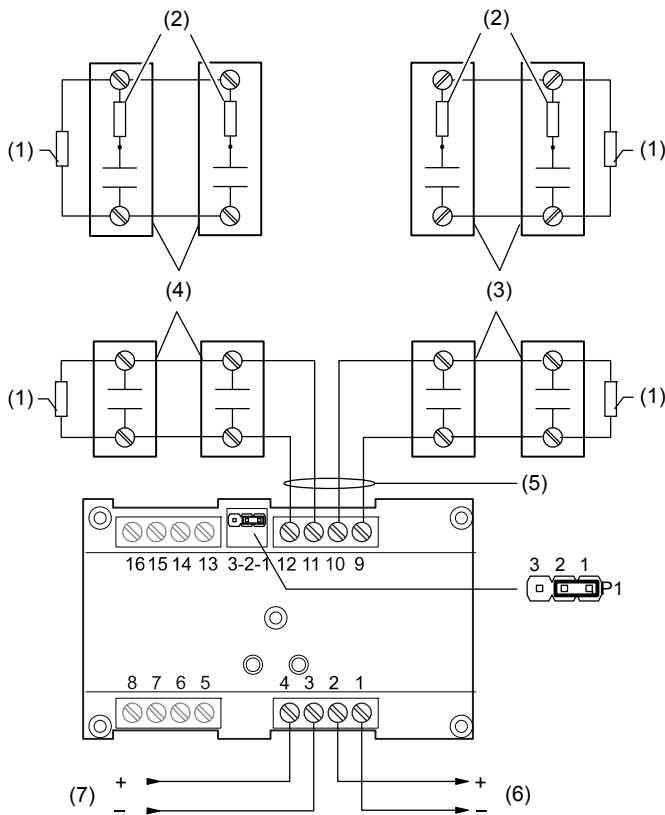
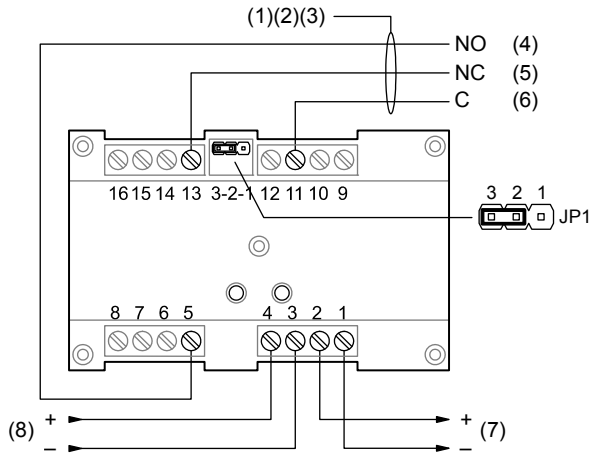
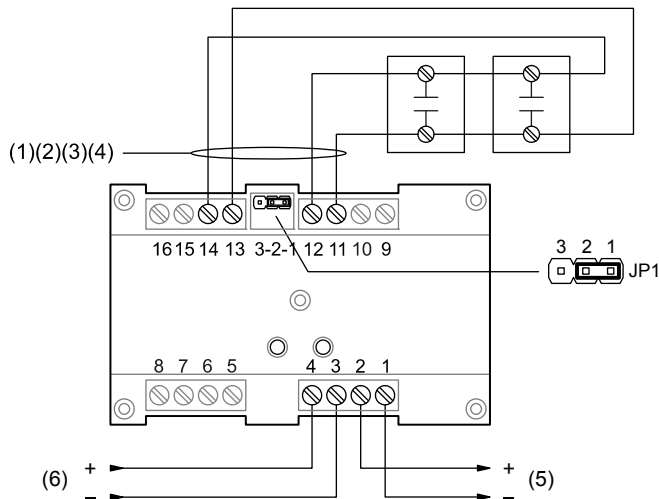

Figure 4: Form C dry contact relay (personality code 8)



- (1) SIGA-UM must be installed in the same room as the device it controls
- (2) Power-limited unless connected to a nonpower-limited source. If the source is nonpower-limited, eliminate the power-limited mark and maintain a minimum of 0.25 in. (6.4 mm) space from power-limited wiring. For other mounting methods, see enclosure and bracket installation sheets to maintain separation of power-limited and nonpower-limited wiring. The wire size must be capable of handling fault current from nonpower-limited source.
— or —
Use type FPL, FPLR, FPLP, or permitted substitute cables, provided these power-limited cable conductors extending beyond the jacket are separated by a minimum of 0.25 in. (6.4 mm) space or by a nonconductive sleeve or nonconductive barrier from all other conductors. Refer to the NFPA 70 *National Electrical Code* for more details.
- (3) The relay function is programmable
- (4) Normally open
- (5) Normally closed
- (6) Common
- (7) Signaling line circuit (SLC) to next device
- (8) Signaling line circuit (SLC) from previous device, power-limited and supervised

Figure 5: Class A initiating device circuit (personality codes 9, 10, 11, 12)



- (1) Input 1: Typical NO initiating device
- (2) 10 VDC at 350 μ A max.
- (3) Maximum 12.5 Ω resistance per wire for Class A configurations.
- (4) Supervised and power-limited unless connected to a nonpower-limited source. If the source is nonpower-limited, eliminate the power-limited mark and maintain a minimum of 0.25 in. (6.4 mm) space from power-limited wiring. For other mounting methods, see enclosure and bracket installation sheets to maintain separation of power-limited and nonpower-limited wiring. The wire size must be capable of handling fault current from nonpower-limited source.
— or —
Use type FPL, FPLR, FPLP, or permitted substitute cables, provided these power-limited cable conductors extending beyond the jacket are separated by a minimum of 0.25 in. (6.4 mm) space or by a nonconductive sleeve or nonconductive barrier from all other conductors. Refer to the NFPA 70 *National Electrical Code* for more details.
- (5) Signaling line circuit (SLC) to next device
- (6) Signaling line circuit (SLC) from previous device, power-limited and supervised

Figure 6: Two-wire smoke detectors and initiating devices (personality codes 13, 14, 20, 21)

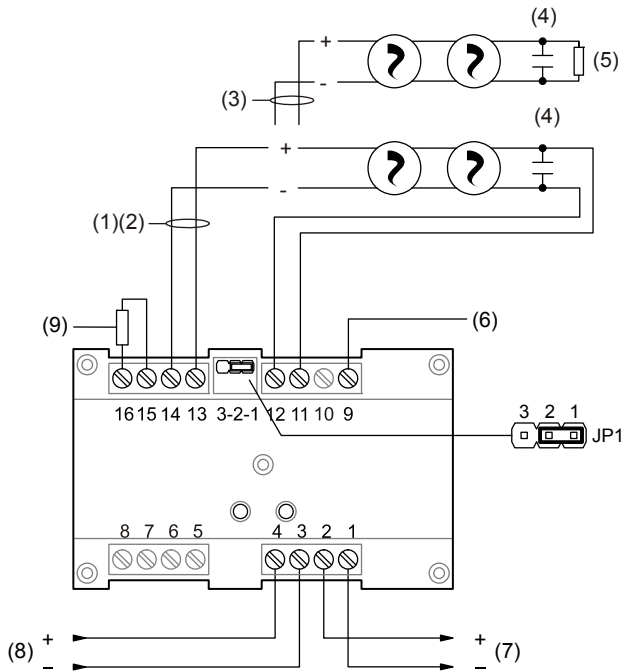

- (1) Class A two-wire smoke circuit
- (2) Maximum 12.5 Ω resistance per wire for Class A configurations
- (3) Class B two-wire smoke circuit
- (4) Not allowed with personality codes 14 and 21
- (5) UL/ULC Listed 15 kΩ EOLR (PN EOL-15) for Class B only
- (6) Smoke detector power (24 VDC) from Signature controller, SMK, or 2-SMK
- (7) Signaling line circuit (SLC) to next device
- (8) Signaling line circuit (SLC) from previous device, power-limited and supervised
- (9) UL/ULC Listed 22 kΩ EOLR (PN EOL-22) for Class A only

Figure 7: Class A or B notification appliance circuit (personality codes 15, 16)

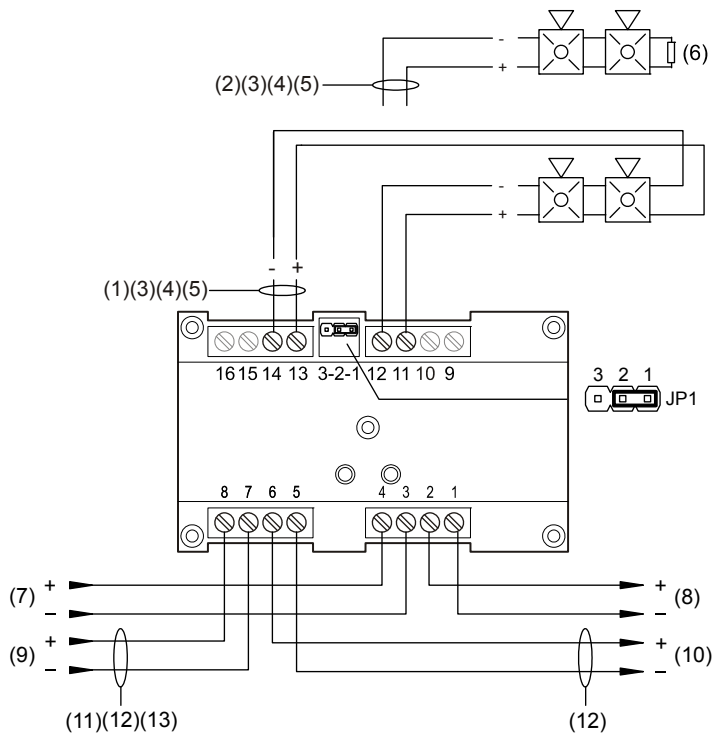



- (1) Class A notification appliance circuit
- (2) Class B notification appliance circuit
- (3) Signal polarity shown when the circuit is normal. Polarity reverses when the circuit is active
- (4) Use twisted pair wires for speaker circuits. All other circuit types use untwisted pair
- (5) Supervised and power-limited unless connected to a nonpower-limited source. If the source is nonpower-limited, eliminate the power-limited mark and maintain a minimum of 0.25 in. (6.4 mm) space from power-limited wiring. For other mounting methods, see enclosure and bracket installation sheets to maintain separation of power-limited and nonpower-limited wiring. The wire size must be capable of handling fault current from nonpower-limited source.
— or —
Use type FPL, FPLR, FPLP, or permitted substitute cables, provided these power-limited cable conductors extending beyond the jacket are separated by a minimum of 0.25 in. (6.4 mm) space or by a nonconductive sleeve or nonconductive barrier from all other conductors. Refer to the NFPA 70 *National Electrical Code* for more details.
- (6) 47 kΩ EOLR (P/N EOL-47) used for Class B only
- (7) Signaling line circuit (SLC) from previous device, power-limited and supervised
- (8) Signaling line circuit (SLC) to next device
- (9) Audio riser (from previous device)
- (10) Audio riser (to next device)
- (11) Power-limited regulated, power supply listed for fire protective signaling use
- (12) Use twisted pair wires for audio riser. All other riser types use untwisted pair.
- (13) If using horns while connected to a compatible fire alarm control panel that does not produce a temporal pattern, a CDR-3 bell coder must be used to comply with ANSI S3.41. This module does not provide signal synchronization.

Specifications

| | |
|---------------------------------------|---|
| Operating voltage range | 15.20 to 19.95 VDC |
| Current | See Table 2 on page 8 |
| Output ratings (special applications) | |
| 24 VDC | 2 A |
| 25 VRMS audio | 50 W |
| 70 VRMS audio | 35 W |
| End-of-Line Resistor | 47 kΩ, UL/ULC listed |
| Circuit capacitance | 0.1 μF max. |
| Initiating device circuit (IDC) | |
| Circuit resistance | 50 Ω max. (25 Ω per wire) |
| Circuit capacitance | 0.1 μF max. |
| Alarm current | 17 mA max. |
| Operating voltage | 16.0 to 24.0 VDC |
| Maximum line impedance | Refer to the fire alarm panel installation manual |
| Ground fault impedance | 10 kΩ |
| Compatible smoke detectors | Refer to the fire alarm panel compatibility list. |
| Two-wire smoke ripple voltage | 2 VAC |
| EOLR part numbers | |
| 15 kΩ | EOL-15 |
| 22 kΩ | EOL-22 |
| 47 kΩ | EOL-47 |
| Circuit designation | |
| Signaling line circuit | Class A, Style 6 or Class B, Style 4 |
| Notification line circuit | Class A, Style Z or Class B, Style Y |
| Initiating device circuit | Class A, Style D |
| Telephone riser circuit | Class B, Style 4 |
| Contact ratings (pilot duty) | 24 VDC at 2 A 120 VAC at 0.5 A |
| Contact type | Form C, programmable |
| Compatible electrical boxes | 2-1/2 in. (64 mm) deep double-gang box; 4 in. square box, 1-1/2 in. (38 mm) deep, with a double-gang cover |
| LPCB/CPR electrical box Requirements | Plastic box with cover plate, no gaps or unused holes |
| Minimum size W × H × D | 3.5 × 3.5 × 1.5 in. (85 × 85 × 38 mm) |
| Wire size | 12 to 18 AWG wire (1.0 to 4.0 mm) |
| Operating environment | |
| Temperature | 32 to 120°F (0 to 49°C) |
| Relative humidity | 0 to 93%, noncondensing |
| Storage temperature range | -4 to 140°F (-20 to 60°C) |

Regulatory information

| | |
|---|--|
| FCC compliance | This device complies with part 15 of the FCC Rules. Operation is subject to the following two conditions: (1) This device may not cause harmful interference, and (2) this device must accept any interference received, including interference that may cause undesired operation. |
| North American standards | UL864, CAN/ULC-S527 |
| EN 54 | EN 54-18: 2005 Input/output devices |
| EU compliance |  |
| CPR certificates | 0832-CPR-F0335 |
|  | 2002/96/EC (WEEE directive): Products marked with this symbol cannot be disposed of as unsorted municipal waste in the European Union. For proper recycling, return this product to your local supplier upon the purchase of equivalent new equipment, or dispose of it at designated collection points. For more information, see: www.recyclethis.info . |

Contact information

For contact information, see www.est-fire.com.

Table 2: Personality code characteristics

| Personality code | Mode of operation | Standby current | Activated current | EOL resistor |
|------------------|---|---------------------------|---|--|
| 1, 2, 3, 4, 18 | Class B initiating device circuit | 458 μ A | 700 μ A | 47 k Ω |
| 8 | Form C dry contact relay | 127 μ A | 120 μ A | N/A |
| 9, 10, 11, 12 | Class A initiating device circuit | 307 μ A | 450 μ A | N/A |
| 13, 14, 20, 21 | Two-wire smoke detectors and initiating devices | 3.1 mA (from 3rd wire) | N/A | Class A: 22 k Ω Class B: 15 k Ω |
| N/A | First UM module to go into alarm (Class A or B) | N/A | 12 mA smoke detector 17 mA contact closure | N/A |
| N/A | Each subsequent UM to go into alarm | N/A | 100 μ A (from data line) | N/A |
| 15, 16 | Class A or B notification appliance circuit | 317 μ A | 140 μ A | Class A: N/A Class B: 47 k Ω |