



Features

- 2-way
- 4" - 6.5" woofer with coaxial tweeter
- 30 W - 60 W / 16 Ω
- 70V / 100V transformer (CV models)
- Tab for safety cable
- Tile bridge pack



CSL-50 / 50CV / 150 / 150CV are compact ceiling speaker specifically designed for commercial applications. It is an ideal solution for restaurants, theme parks, retail stores, commercial centres, office buildings, airports and other applications where background music and paging are required.

Equipped with a large magnet 4/ 6.5" woofer and a coaxial 3/4" dome tweeter, CSL-50 / 50CV / 150 / 150CV deliver warm and punchy sound at all levels. The sound reproduction is perfect for both speech and music.

The units operate at 16 Ω or 100V line for the CV versions. On CV models a selector is available to switch from low impedance to 100 V taps at 7.5, 15, 30 W (CSL-50CV) and 15, 30, 60 W (CSL-150CV). The 16 Ω output is particularly useful for parallel connections when a 100 V line is not required.

CSL-50 / 50CV / 150 / 150CV can be installed in a solid or tile ceiling; a tile bridge pack is included with each speaker. The steel back-can is rated to safety standards and offers an easy access to the connections and settings.



CSL-50



CSL-150

Specifications

MODEL	CSL-50 / CSL-50CV	CSL-150 / CSL-150CV
Transducers	4" polypropylene woofer (105 mm) 3/4" coaxial tweeter (19 mm)	6.5" polypropylene woofer (165 mm) 3/4" coaxial dome tweeter (19 mm)
Max power	20 W RMS - 30 W MAX	30 W RMS - 60 W MAX
Output	16 Ohms 70 V : 3.5 W, 7.5 W, 15 W, 30 W (CV models) 100 V : 7.5 W, 15 W, 30 W (CV models)	16 Ohms 70 V : 7.5 W, 15 W, 30 W, 60 W (CV models) 100 V : 15 W, 30 W, 60 W (CV models)
Impedance 70V/100V	1 327, 656, 328, 164 Ohms	656, 328, 164, 82 Ohms
Frequency response	100 Hz - 20 kHz @ -10 dB	90 Hz - 20 kHz @ -10 dB
Sensitivity	86 dB (1 m /1 W)	92 dB (1 m /1 W)
Coverage	100° conical	100° conical
Outside Dimensions	Diam. = 212 mm	Diam. = 252 mm
Cut-out size	Diam. = 181 mm	Diam. = 221 mm
Dome	Steel	Steel
Mounting	Dog ear flip tabs	Dog ear flip tabs
Weight	CSL-50: 2.7 kg (5.95 lbs.) CSL-50CV: 3.5 kg (7.72 lbs.)	CSL-150: 3.4 kg (7.5 lbs.) CSL-150CV: 6.3 kg (13.89 lbs.)
Accessories	C-shaped support plate + Tile support rails	C-shaped support plate + Tile support rails

Specifications subject to modification without notice

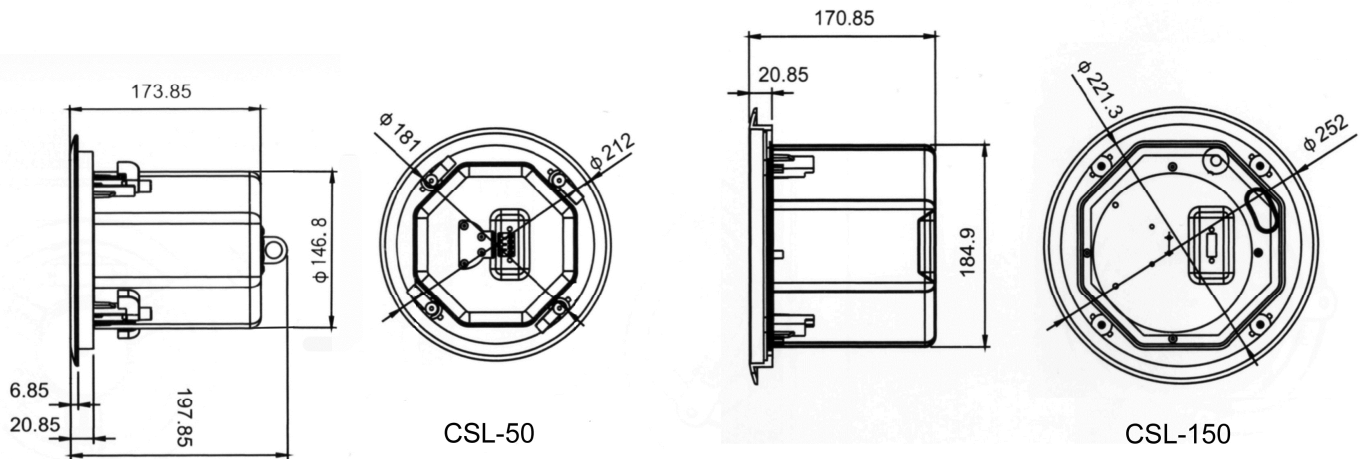

CSL-50

CSL-150

Tile bridge bracket

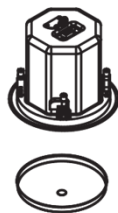
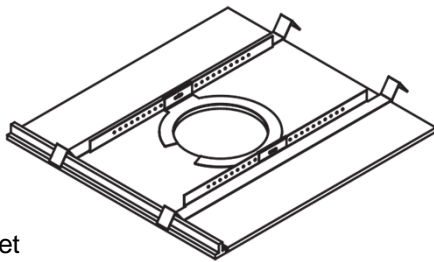

Input Terminals



SEIKAKU TECHNICAL GROUP LIMITED

NO.1 LANE 17, SEC.2, HAN SHI WEST ROAD, TAICHUNG 40151 TAIWAN

Tel: +886-4-22313737 Fax: +886-4-22346757 www.seikaku.hk