

# Intelligent Duct Smoke Detector

## SIGA-SD

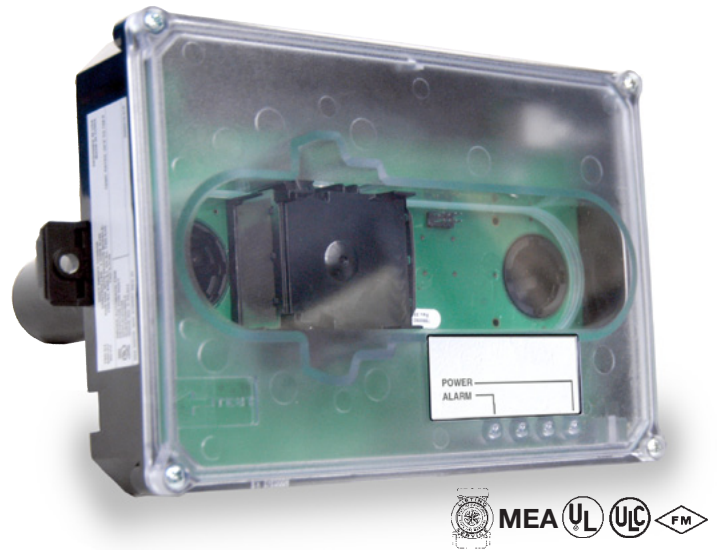

### Overview

The Edwards *SuperDuct* Signature Series smoke detector is the most advanced and most reliable device in its class. Designed for easy installation and superb reliability, *SuperDuct* represents the perfect balance of practical design and advanced technology.

**SuperDuct detectors** feature a unique design that speeds installation and simplifies maintenance. Removable dust filters, conformally coated circuit boards, and optional water-resistant gaskets keep contaminants away from components, ensuring years of trouble-free service. When cleaning is required, the assemblies come apart easily and snap back together in seconds.

A **Signature Series photoelectric sensor** is incorporated into the design of each SIGA-SD duct smoke detector. This sensor inherits the power and benefits of this exceptional line of intelligent devices.

Signature Series sensors gather analog information from their smoke sensing elements and convert it into digital signals. The sensor measures and analyses these signals and compares the information to historical readings and time patterns to make an alarm decision. Digital filters remove signal patterns that are not typical of fires, which virtually eliminates unwanted alarms.

**WARNING:** Duct detectors have specific limitations. Duct detectors are not a substitute for an open area smoke detector. Duct detectors are not a substitute for early warning detection or a replacement for a building's regular fire detection system. Smoke detectors are not designed to detect toxic gases which can build up to hazardous levels in some fires. These devices will not operate without electrical power. As fires frequently cause power interruptions, Edwards suggests you discuss further safeguards with your local fire protection specialist.

### Standard Features

- Less than 2" deep for easy installation and applications where space is tight
- -4°F to 158°F (-20°C to 70°C) operating range with 100 ft/min. to 4,000 ft/min air velocity rating assures reliability under harsh environmental conditions
- Status LEDs remain visible through clear assembly cover
- Cover monitor switch for added security
- Standard sampling tube spacing for easy drop-in migration from other detectors
- Sampling tube can be installed with or without the cover in place and can be rotated in 45-degree increments to ensure proper alignment with duct airflow
- 15.2 to 19.95 Vdc operation
- Magnet-activated test switch
- One Form C auxiliary alarm relay for controlling ancillary equipment (e.g., HVAC controls)
- No special tools required for easy access to field connections
- Signature Series intelligence
- Environmental compensation with differential sensing for reliable, stable, and drift-free sensitivity
- Wide 0.79% to 2.46% obscuration/ft. smoke sensitivity
- Identification of dirty or defective detectors

## Application

*SuperDuct* detectors are ideally suited to duct smoke detection applications where early indication of combustion is required within the confined space of ventilation ductwork. Its primary purpose is to provide early warning of an impending fire and to prevent smoke from circulating throughout the building. It is typically used to detect smoke in the supply side of the HVAC system but can provide supervision of the return side as well.

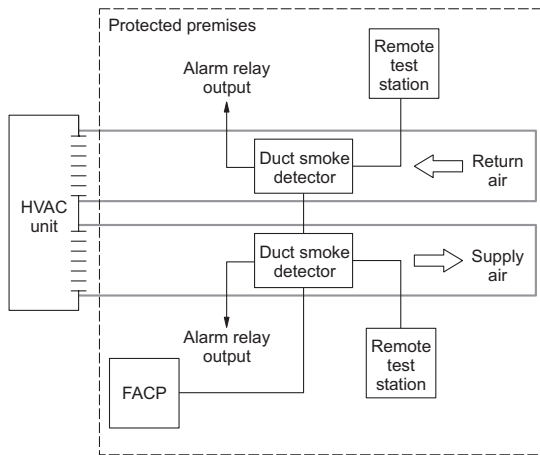

*SuperDuct* detectors continually sample air flow in the HVAC duct and initiate an alarm condition whenever smoke is detected. An alarm is activated when the quantity (percent obscuration) of combustion products in that air sample exceeds the detector's sensitivity setting.

### Signature Series Intelligence

Like all Signature detectors, the SIGA-SD features electronic addressing and issues a dirty sensor warning when it reaches its preset limit. The dirty sensor warning indicates the sensor is operating within its specified limits but is in need of servicing. When the detector's ability to compensate for environmental changes has reached its limit, the duct smoke detector signals a trouble condition.

The SIGA-SD also uses differential sensing to prevent gradual environmental changes from triggering unwanted alarms. A rapid change in environmental conditions, such as smoke from a fire, causes the detector to signal an alarm state, but dust and debris accumulated over time does not change alarm sensitivity.

Each Signature Series *SuperDuct* detector contains a microprocessor that performs comprehensive self-diagnostics and stores the results in nonvolatile memory. Stored results include details such as hours of operation, last maintenance date, and number of alarms and troubles. This information can be retrieved and reviewed when desired.

### Detector Configuration

The detector assembly cover provides easy access to the smoke sensor, its wiring connections, sample and exhaust tubes, and the smoke chamber itself.

Air enters the detector's sensing chamber through a sampling tube (ordered separately) that extends into the duct and is directed back into the ventilation system through an exhaust tube (included). The difference in air pressure between the two tubes pulls the sampled air through the sensing chamber. When a sufficient amount of smoke is detected in the sensing chamber, the detector initiates an alarm.

The sampling tube may be installed from either the duct side of the assembly or from inside the sensor compartment, as preferred by the installer. (The exhaust tube must be installed from the duct side.) Sampling tubes may be rotated in 45-degree increments so that air-holes can be aligned to allow the unit to be mounted at virtually any angle relative to the air flow.

In installations where the duct smoke detector's controls and indicators are hidden from view, a remote test station or an LED indicator can be connected to the detector to provide these functions.

### Remote Test Stations



Labor-saving Remote Test/Reset stations provide alarm testing from the convenience of a remote location. Tests can be performed quickly and safely – without having to climb to the roof. Magnetically-operated and key-operated one-gang models are available. Signature *SuperDuct* detectors are also compatible with SIGA-LED remote alarm LED.

Air velocity in the duct as low as 100 ft/min. maintains adequate air flow into the sensor smoke chamber through air holes in the air sampling tube and discharges through the exhaust tube. *SuperDuct* air sampling tubes must be installed with the inlet holes facing the airstream. Sampling tubes may be rotated in 45-degree increments so that air-holes can be aligned to allow the unit to be mounted in virtually any angle relative to the airflow.

*SuperDuct* sensors are engineered to operate optimally under the harsh environmental conditions frequently found in HVAC ductwork. Nonetheless, before installing the detector, test the duct air velocity, temperature, and humidity to verify that it is within the operating range of the *SuperDuct* detector. Consult the *SuperDuct* installation sheet for details.

## Dimensions

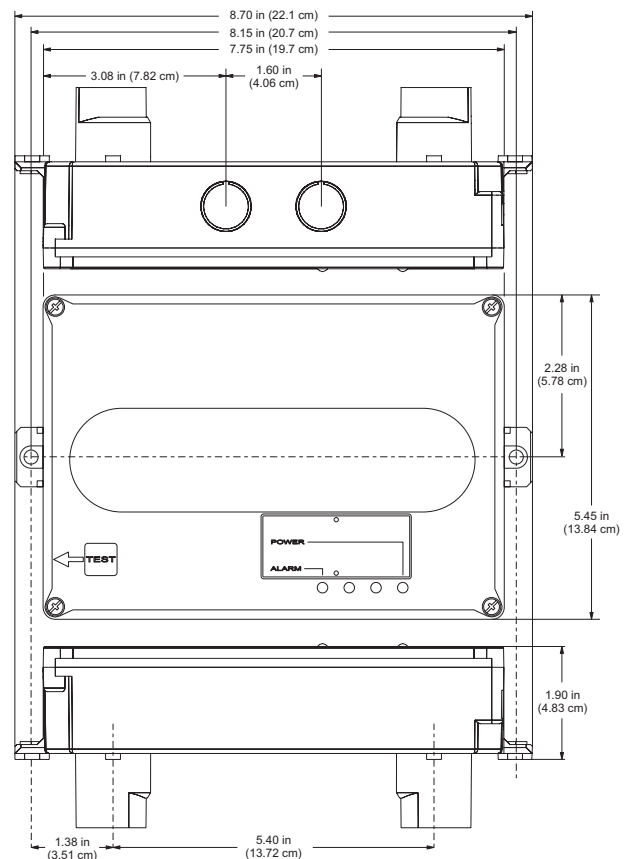

## Assembly

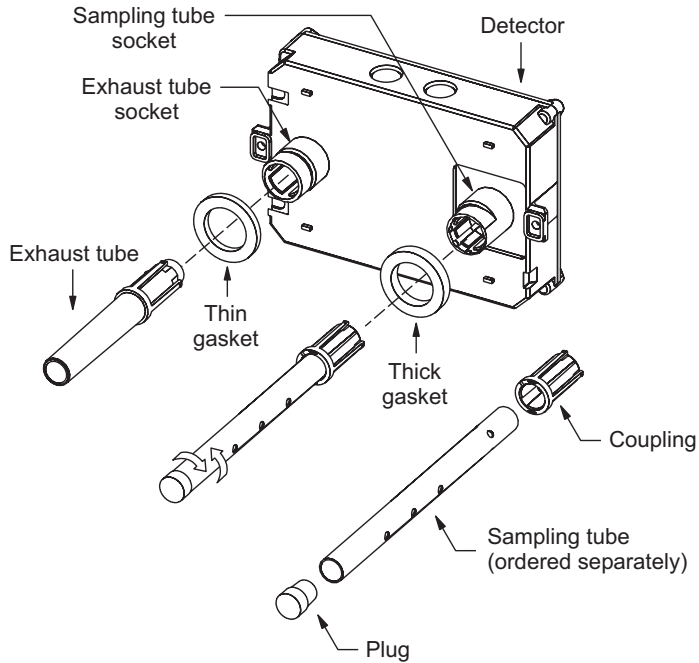

## Mounting

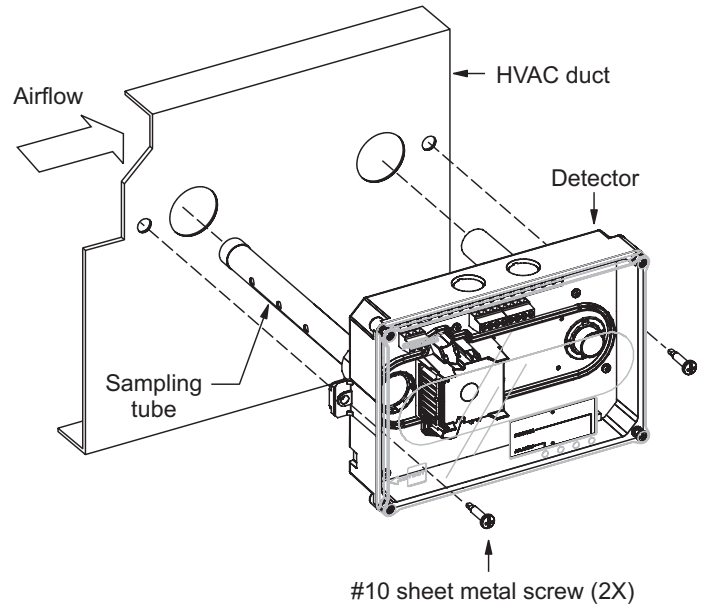

## Wiring

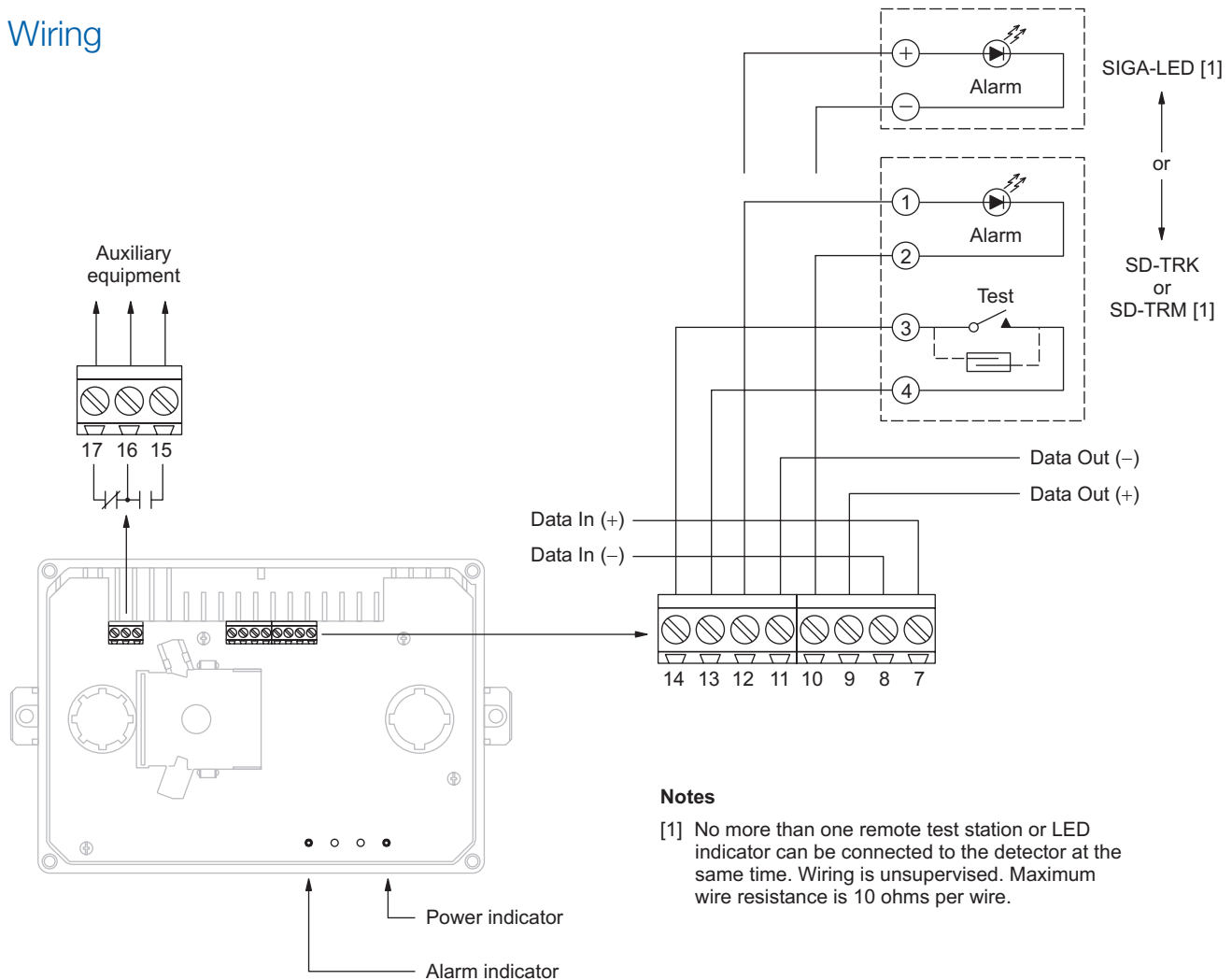

### Notes

- [1] No more than one remote test station or LED indicator can be connected to the detector at the same time. Wiring is unsupervised. Maximum wire resistance is 10 ohms per wire.



**Detection & alarm since 1872**

**U.S.**  
**T 888-378-2329**  
**F 866-503-3996**

**Canada**  
**Chubb-Edwards**  
**T 519 376 2430**  
**F 519 376 7258**

**Southeast Asia**  
**T : +65 6391 9300**  
**F : +65 6391 9306**

**India**  
**T : +91 80 4344 2000**  
**F : +91 80 4344 2050**

**Australia**  
**T +61 3 9239 1200**  
**F +61 3 9239 1299**

**Europe**  
**T +32 2 725 11 20**  
**F +32 2 721 86 13**

**Latin America**  
**T 305 593 4301**  
**F 305 593 4300**

[utcfireandsecurity.com](http://utcfireandsecurity.com)

© 2010 UTC Fire & Security.  
 All rights reserved.

## Specifications, detector

Dimensions	8.70 x 5.45 x 1.90 inches (221 x 138 x 48 mm)
Wire size	14 to 22 AWG
Detection method	Photoelectric (light scattering principle)
Air velocity rating	100 to 4,000 ft/min and meets the required minimum air pressure differential
Air pressure differential	0.005 to 1.00 inches of water
Sensitivity	0.79 to 2.46 %/ft obscuration
Alarm test response time	5 seconds
LED indicators	Alarm (red), Power (green)
Common alarm relay	Unsupervised and power-limited Quantity: 1 Type: Form C Ratings: 2.0 A at 30 Vdc (resistive)
Operating voltage	15.2 to 19.95 Vdc
Operating current	Standby: 45 µA Alarm: 45 µA Inrush: 1 mA Standalone alarm: 18 mA
Operating environment	Temperature (UL): -4 to 158 °F (-29 to 70 °C). Temperature (ULC): -4 to 120 °F (-29 to 49 °C) Relative humidity: 10 to 93%, noncondensing
Agency listings	UL, ULC, CSFM, FM, MEA

## Specifications, test stations

Remote Test/Reset Stations provide alarm test, trouble indication, and reset capability from a remote location. They include a one-gang plate, momentary SPST switch, red alarm LED, and terminal block. Magnetically-operated models (TRM) or key-operated models (TRK) are available.

Compatible electrical boxes	North American 1-gang box Standard 4-in square box, 1-1/2 inches deep, with 1-gang cover
LED indicators	Alarm (red)
LED type	Clear lens
Wire size	14 to 22 AWG
Resistance per wire	10 Ohms, max.
Current requirements	See controller specifications
LED circuit ratings	Voltage: 3 Vdc, max. Current: 30 mA, max.
Switch ratings (SD-TRK)	Voltage: 125 Vdc, max. Current: 4 A, max.
Switch ratings (SD-TRM)	Voltage: 200 Vdc, max. Current: 0.5 A, max.
Compatible detectors	SuperDuct conventional two-wire and Signature duct smoke detectors
Operating environment	-4°F to 158°F (-20°C to 70°C) Humidity: 93% RH, noncondensing
Storage temperature	-4 to 140 °F (-20 to 60 °C)
Agency listings	UL, ULC, CSFM

## Ordering Information

Catalog Number	Description	Ship Wt., lb. (kg)
SIGA-SD	Intelligent SuperDuct Detector	2.4 (1.1)
<b>Accessories</b>		
SD-T8	8-inch sampling tube	0.5 (0.2)
SD-T18	18-inch sampling tube	1.5 (0.7)
SD-T24	24-inch sampling tube	2.7 (1.2)
SD-T36	36-inch sampling tube	3.0 (1.4)
SD-T42	42-inch sampling tube	3.5 (1.6)
SD-T60	60-inch sampling tube	5.8 (2.6)
SD-T78	78-inch sampling tube	7.5 (3.4)
SD-T120	120-inch sampling tube	11.5 (5.2)
SIGA-LED	Remote alarm LED	1.0 (0.5)
SD-TRM	Remote test station, magnetic	1.0 (0.5)
SD-TRK	Remote test station, keyed	1.0 (0.5)
SD-VTK	Air velocity test kit (stoppers only, etc)	1.0 (0.5)
SD-GSK	Cover gasket kit	0.5 (0.2)
SD-MAG	Test magnet kit	0.5 (0.2)
SIGA-SDPCB	Replacement PCB/Signature sensor kit	1.0 (0.5)