

## Model WMA-1 Water Motor Alarm Hydraulically Operated Mechanical Sprinkler Alarm European Conformity, 16 Bar

### General Description

The Model WMA-1 Water Motor Alarm is a hydraulically operated outdoor alarm designed for use with fire protection system waterflow detection valves. It is lightweight yet rugged, and it can be used in conjunction with alarm check, dry pipe, deluge, and preaction valves to sound a local alarm.

The Water Motor Alarm is suitable for mounting to any type of rigid wall and can accommodate a wall thickness range of 50 to 450 mm. It is provided with a listed and approved Model 74A Y-Strainer (P/N 305004) for use in the alarm line.

The WMA-1 utilizes a lightweight, impeller design which can produce a very high sound pressure level. The Gong, Gong Mount, and Water Motor Housing are fabricated from corrosion resistant aluminum alloys with a brass nozzle insert. The polymer drive bearings do not require lubrication, and the Gong is closely fitted to the Gong Mount to eliminate the need for a separate cover.

#### **WARNING**

*The Model WMA-1 Water Motor Alarm described herein must be installed and maintained in compliance with this document in addition to the standards recognized by the Approval agency, as well as the standards of any other authorities having jurisdiction. **Failure to do so may impair the performance of this device.***

*The owner is responsible for maintaining their fire protection system and devices in proper operating condition. The installing contractor or sprinkler manufacturer should be contacted with any questions.*

### Technical Data

**Approvals**  
CE, FM, and VdS Approved.

**Gong Finish**  
Red or Aluminum

**Working Water Pressure Range**  
0,5 to 16,0 bar

**Nozzle K-Factor**  
10,1 LPM/bar<sup>1/2</sup>

**Y-Strainer**  
DN20, bronze, 0,65 mm mesh screen.

**Trim Components**  
Galvanized steel nipples and cast iron fittings.

### Design Data

The Model WMA-1 Water Motor Alarm must be used in accordance with the following design criteria:

**Item 1.** The Y-Strainer is to be located at the inlet to the Water Motor Alarm (Ref. Figure 2).

**Item 2.** The Water Motor Alarm must only be mounted to a rigid wall surface, which will not permit the Striker/Gong Mount to loosen and fall out of alignment.

**Item 3.** In order to obtain the highest possible sound level, the Water Motor Alarm should be located as close as possible to the waterflow detecting valve.

**Item 4.** The alarm line piping from the alarm outlet of the waterflow detection valve trim to the Water Motor Alarm must be DN20 inch size throughout and it must be galvanized steel, brass, or other suitable corrosion resistant material.

**Item 5.** The alarm line piping must be positioned such that it can be drained



back to the water flow detection valve trim.

**Item 6.** The Clean-Out Sump Plug is to be located vertically below the Inlet to the Water Motor.

**Item 7.** Piping from the Water Motor Drain must be a minimum of DN25 inch in size throughout and directed to an open drain, in order to ensure proper drainage for obtaining the maximum sound pressure level.

#### **NOTE**

*The Water Motor Alarm Drain may be connected to the main drain of a water flow detection valve if a non-spring loaded swing type check valve is installed in a horizontal portion of the water motor alarm drain piping (before its connection to the main drain).*

**Item 8.** In order to minimize any wall staining that can be created by drain water, it is recommended that the drain piping from the Water Motor be galvanized steel, brass, or other suitable corrosion resistant material.

**Item 9.** Drain water must be directed such that there will be no accidental damage to property or danger to persons when the alarm is operating or thereafter.

**Item 10.** The alarm line drain (at the waterflow detection valve) must be maintained at a minimum temperature of 4°C.

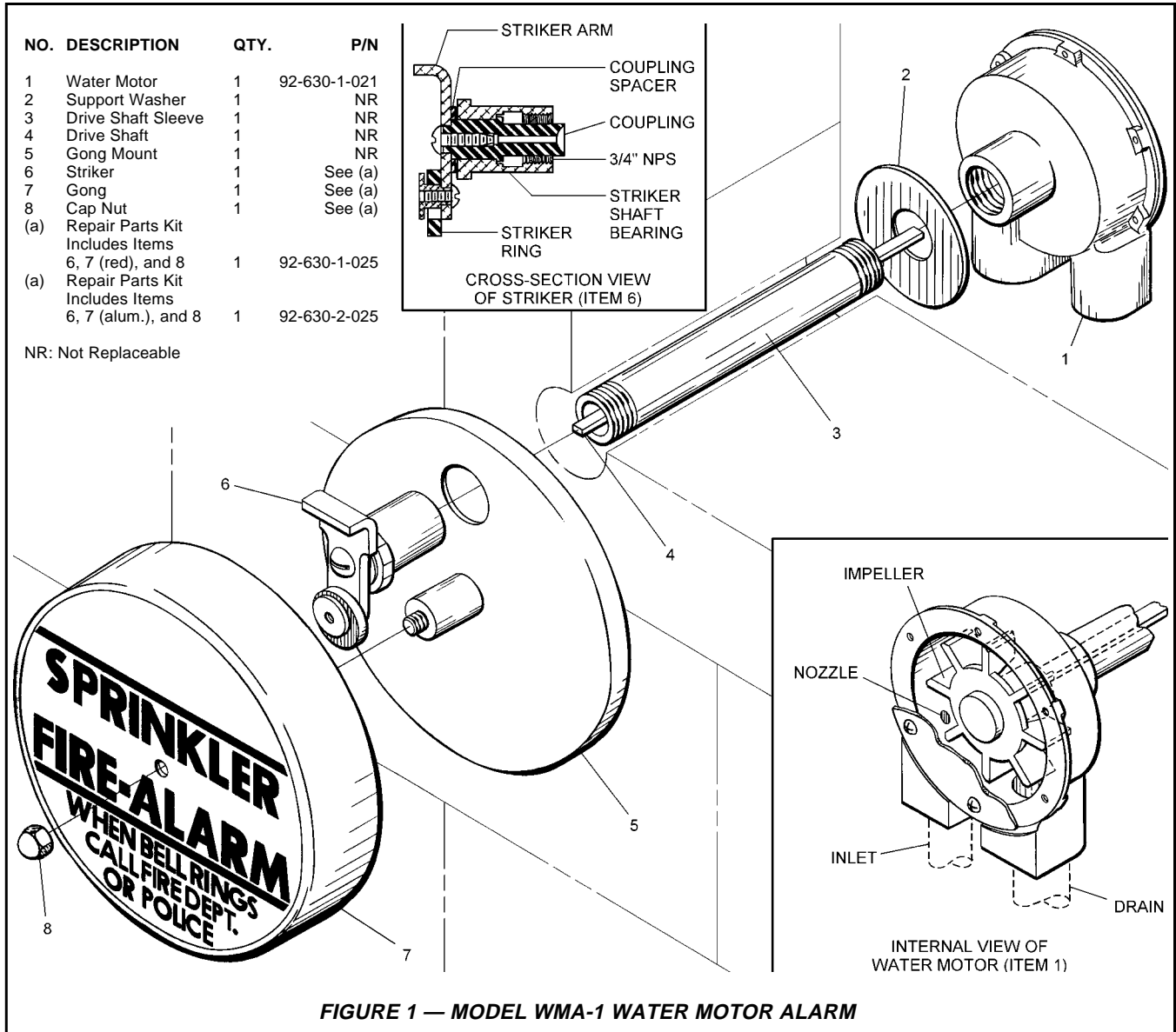

## Operation

Upon operation of the alarm check, dry pipe, deluge, or preaction valve to which the Model WMA-1 Water Motor Alarm is connected, water will flow to the Water Motor and through the Inlet Nozzle. As water flows through the Inlet Nozzle, a high velocity jet is formed which impinges on the Impeller, causing the Impeller and the Striker to rotate. With each rotation, the free swinging Striker Ring hits the Gong and sounds the alarm. The spent water is then drained through the 1 inch outlet.

The alarm will sound as long as water is flowing into the system and flowing to the Water Motor Alarm. Water in the alarm line will automatically drain back through the orifice which is also pro-

vided in the trim of the waterflow detection valve.

The Water Motor Alarm does not have to be reset after an operation. However, if the alarm was silenced during operation by closing of an alarm control valve, the alarm control valve must be reopened after the fire protection system is restored to service.

## Installation

The Model WMA-1 Water Motor Alarm must be installed in accordance with the following instructions:

**Step 1.** Mark the through-wall locations for the centerlines of the Sleeve and Drain Outlet. The Drain Outlet must be located at least 250 mm below the Sleeve per Figure 2.

**Step 2.** Make 38 mm diameter holes straight through the wall at both locations.

**Step 3.** Cut the non-threaded end of the Sleeve to a length equal to that of the wall thickness plus 0 to 3 mm. Thread the cut end to ISO 7-R3/4 per ISO 7-1.

**Step 4.** Install the alarm line piping up to and including the union half, Item 4 - Fig. 2.

### NOTE

Use thread sealant sparingly on male threads only.

**Step 5.** Prior to initiating installation of the Water Motor Alarm, mount the Drain Trim (less the Wall Plate and 45° Elbow), as well as the balance of alarm line piping (including other union half) to the Water Motor.

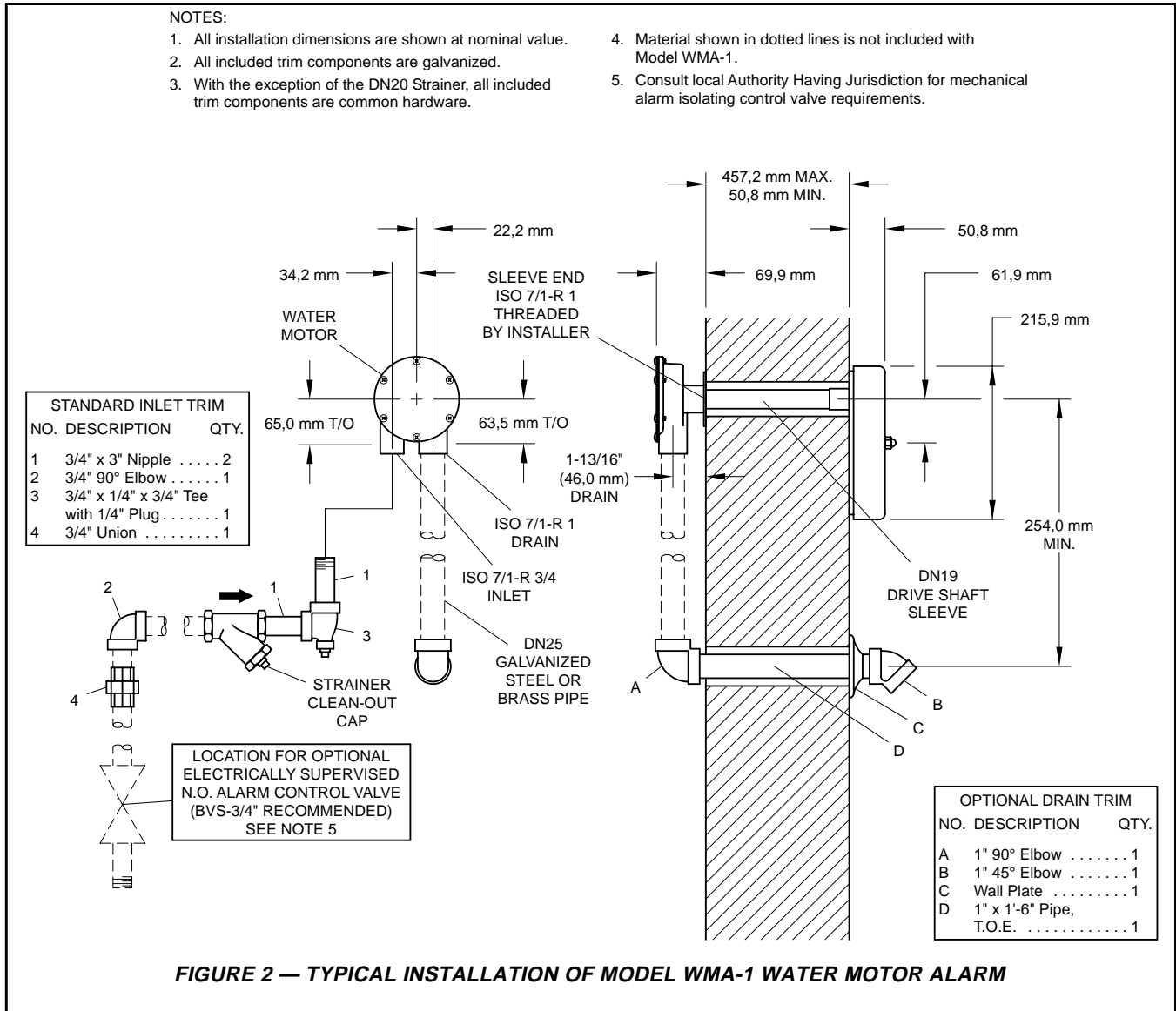

**Step 6.** Tighten the ISO threaded end of the Sleeve into the Body hand tight plus 1/8 turn.

**Step 7.** Slip the Support Washer over the Sleeve and place the assembly in position against the wall.

**Step 8.** Tighten the DN20 inch Union. Install the Wall Plate and tighten the 45° Elbow.

**NOTE**

Apply pressure against the outside edge of the Water Motor Body and verify that the Body and Support Washer sit square against the wall. If not, adjust the alarm line and/or drain piping to suit.

**Step 9.** From the outside wall, insert the Drive Shaft through the Sleeve and fully insert it into the Impeller. (When fully inserted, the Shaft should protrude beyond the face of the wall by

approximately 500 mm minus 50mm minus wall thickness.)

Mark the Drive Shaft at a point of approximately 3 to 6 mm inside the face of the wall; remove the Shaft; cut the Shaft where previously marked; file off burrs from the cut end of the Drive Shaft; and, re-insert the Drive Shaft through the Sleeve and fully insert it into the Impeller.

**Step 10.** Hold the Gong Mount in position against the wall, engage the Coupling with the Drive Shaft and then carefully thread the Striker Shaft Bearing onto the Sleeve. Securely tighten the Striker Shaft Bearing using a pair of channel locks on the 38 mm hex end.

**Step 11.** Spin the Striker by hand and verify that it spins freely (without any

sign of binding). If not, make the necessary adjustments.

**Step 12.** Install the gong and securely tighten the Cap Nut. The identification sign lettering must be orientated horizontally,

**Step 13.** Test the Water Motor Alarm by opening the alarm test valve in the trim of the water flow detection valve. The alarm must be clear and steady. If not, make the necessary adjustments.

**NOTE**

Testing of the Water Motor Alarm may result in operation of other associated alarms. Consequently, notification must be given to the owner and the fire department, central control station, or other signal station to which the alarms are connected.

## Care and Maintenance

The following procedures and inspections should be performed as indicated, in addition to any specific requirements of the authority having jurisdiction, and any impairment must be immediately corrected.

The owner is responsible for the inspection, testing, and maintenance of their fire protection system and devices in compliance with this document, as well as in addition to the standards of any authority having jurisdiction. The installing contractor or product manufacturer should be contacted relative to any questions.

It is recommended that automatic sprinkler systems be inspected, tested, and maintained by a qualified Inspection Service in accordance with local requirements and/or national codes.

### NOTES

*Before closing a fire protection system main control valve for maintenance work on the fire protection system that it controls, permission to shut down the affected fire protection systems must first be obtained from the proper authorities and all personnel who may be affected by this decision must be notified.*

*Testing of the Water Motor Alarm may result in operation of other associated alarms. Consequently, notification must be given to the owner and the fire department.*

*If the alarm was silenced during operation, the alarm control valve must be reopened immediately after the fire protection system is restored to service.*

The Model WMA-1 Water Motor Alarm must be maintained and serviced in accordance with the following instructions:

**Step 1.** The Model WMA-1 Water Motor Alarm does not require any regularly scheduled maintenance. Rotating parts do not require lubrication. It is recommended, however, that fire alarms be periodically operated, i.e., inspected, to verify that they generate a clear and steady sound. Any impairment must be immediately corrected.

**Step 2.** The inspection should be made periodically in accordance with the requirements of the authority having jurisdiction, or more frequently as may be necessary in the case of locations subject to vandalism. The Y-Strainer and the Reducing Tee at the WMA-1 inlet are to be cleaned out after each operation of the Water Mo-

tor Alarm and after the alarm line piping has been drained.

## Limited Warranty

Products manufactured by Tyco Fire & Building Products are warranted solely to the original Buyer for ten (10) years against defects in material and workmanship when paid for and properly installed and maintained under normal use and service. This warranty will expire ten (10) years from date of shipment by Tyco Fire & Building Products. No warranty is given for products or components manufactured by companies not affiliated by ownership with Tyco Fire & Building Products or for products and components which have been subject to misuse, improper installation, corrosion, or which have not been installed, maintained, modified or repaired in accordance with the standards recognized by the Approval agency, as well as the standards of any other authorities having jurisdiction. Materials found by Tyco Fire & Building Products to be defective shall be either repaired or replaced, at Tyco Fire & Building Products' sole option. Tyco Fire & Building Products neither assumes, nor authorizes any person to assume for it, any other obligation in connection with the sale of products or parts of products. Tyco Fire & Building Products shall not be responsible for sprinkler system design errors or inaccurate or incomplete information supplied by Buyer or Buyer's representatives.

IN NO EVENT SHALL TYCO FIRE & BUILDING PRODUCTS BE LIABLE, IN CONTRACT, TORT, STRICT LIABILITY OR UNDER ANY OTHER LEGAL THEORY, FOR INCIDENTAL, INDIRECT, SPECIAL OR CONSEQUENTIAL DAMAGES, INCLUDING BUT NOT LIMITED TO LABOR CHARGES, REGARDLESS OF WHETHER TYCO FIRE & BUILDING PRODUCTS WAS INFORMED ABOUT THE POSSIBILITY OF SUCH DAMAGES, AND IN NO EVENT SHALL TYCO FIRE & BUILDING PRODUCTS' LIABILITY EXCEED AN AMOUNT EQUAL TO THE SALES PRICE.

**THE FOREGOING WARRANTY IS MADE IN LIEU OF ANY AND ALL OTHER WARRANTIES EXPRESS OR IMPLIED, INCLUDING WARRANTIES OF MERCHANTABILITY AND FITNESS FOR A PARTICULAR PURPOSE.**

## Ordering Information

Orders for the WMA-1, Optional Drain Trim, and replacement parts must include the description and Part Number (P/N).

The Complete Model WMA-1 Alarm Assembly includes the Model WMA-1 Water Motor Alarm, Model 74A Strainer, and Standard Inlet Trim.

### WMA-1 Alarm Assemblies:

Specify: Model WMA-1 Alarm Assembly with Red Finish Gong, P/N 52-630-1-021.

Specify: Model WMA-1 Alarm Assembly with Aluminum Finish Gong, P/N 52-630-2-021.

### Optional Drain Trim:

Specify: Optional Drain Trim for Model WMA-1 Water Motor Alarm, P/N 526302002E.

### Replacement Parts for Water Motor Alarm:

(Specify description) for use with Model WMA-1 Water Motor Alarm, P/N (see Figure 1).

Model 74A Y-Strainer, P/N 305004.