

Intercom Surface-mount Box

For a Two-module DHI-VTO4202F Series Modular Door Station



Technical Specification

Material	5052 Aluminum
Color	Silver
Installation Method	Surface-mount
Dimensions (W x H x L)	144.80 mm x 241.20 mm x 52.0 mm (5.70 in. x 9.50 in. x 2.05 in.)
Ingress Protection	IP65 (Silicone sealant required)
Net Weight	0.45 kg (1.0 lb)
Gross Weight	0.64 kg (1.41 lb)
Compatibility	<ul style="list-style-type: none"> DHI-VTO4202F Series Modular Door Station (two-module system) VTM125 Intercom Front Panel Bezel

Installation

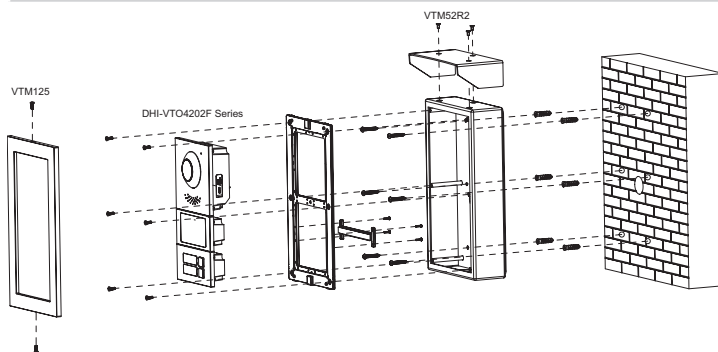

Dimensions (mm/in.)

